

Steel Column Design Steel Connections

- Capacity Analysis of Steel Columns
- Design of Steel Columns
- Connection Types
- Connection Analysis

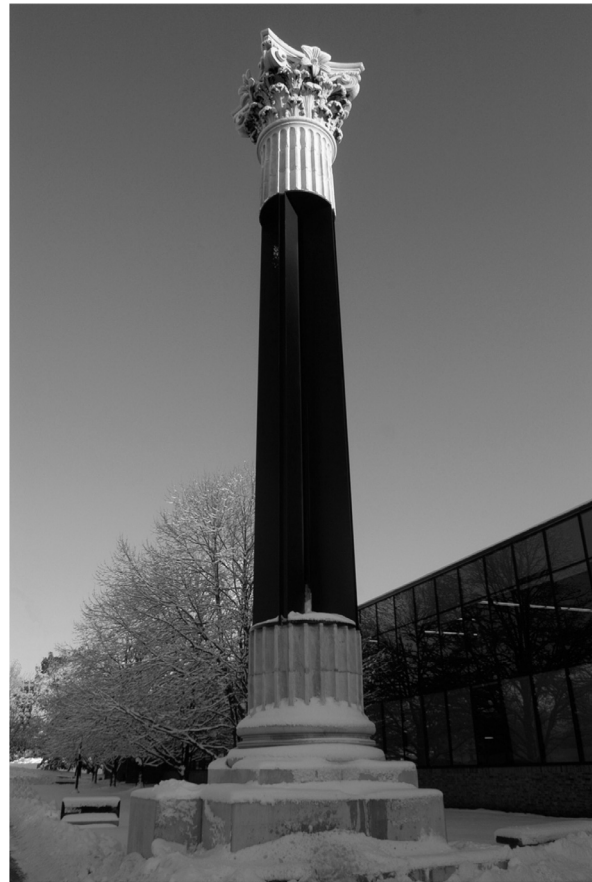

Design of Steel Columns with AISC Strength Tables

Data:

- Column – length
- Support conditions
- Material properties – F_y
- Applied design load - P_u

Required:

- Column Size

1. Enter table with height, $KL = L_c$
2. Read allowable load for each section to find the smallest adequate size.
3. **Tables assume weak axis buckling. If the strong axis controls the length must be divided by the ratio r_x/r_y**
4. Values stop in table (black line) at slenderness limit, $KL/r = 200$

4-24

DESIGN OF COMPRESSION MEMBERS

Shape		W8x											
		67		58		48		40		35		31	
Design		P_n/Ω_c	$\phi_c P_n$	P_n/Ω_c	$\phi_c P_n$	P_n/Ω_c	$\phi_c P_n$	P_n/Ω_c	$\phi_c P_n$	P_n/Ω_c	$\phi_c P_n$	P_n/Ω_c	$\phi_c P_n$
Effective length, L_c (ft), with respect to least radius of gyration, r_y	0	590	886	512	769	422	634	350	526	308	463	273	411
	6	542	815	470	706	387	581	320	481	281	423	249	374
	7	526	790	455	685	375	563	309	465	272	409	241	362
	8	508	763	439	660	361	543	298	448	262	394	232	348
	9	488	733	422	634	347	521	285	429	251	377	222	333
	10	467	701	403	606	331	497	272	409	239	359	211	317
	11	444	668	384	576	314	473	258	388	226	340	200	301
	12	421	633	363	546	297	447	243	366	213	321	189	283
	13	397	597	342	514	280	421	228	343	200	301	177	266
	14	373	560	321	482	262	394	213	321	187	281	165	248
	15	348	523	299	450	244	367	198	298	174	261	153	230
	16	324	487	278	418	226	340	183	275	160	241	141	212
	17	300	450	257	386	209	314	169	253	147	221	130	195
	18	276	415	236	355	192	288	154	232	135	203	118	178
	19	253	381	216	325	175	264	141	211	123	184	108	162
	20	231	347	197	296	159	239	127	191	111	166	97.2	146
	22	191	287	163	244	132	198	105	158	91.5	138	80.3	121
	24	160	241	137	205	111	166	88.2	133	76.9	116	67.5	101
	26	137	205	116	175	94.2	142	75.2	113	65.5	98.5	57.5	85.5
	28	118	177	100	151	81.2	122	64.8	97.4	56.5	84.9	49.6	74.5
30	103	154	87.5	131	70.7	106	56.5	84.9	49.2	74.0	43.2	64.9	
32	90.3	136	76.9	116	62.2	93.5	49.6	74.6	43.3	65.0	38.0	57.1	
34	79.9	120	68.1	102	55.1	82.8	44.0	66.1					
Properties													
P_{max} , kips	126	190	102	153	72.0	108	57.2	85.9	45.9	68.9	39.4	59.1	
P_{max} , kip/in.	19.0	28.5	17.0	25.5	13.3	20.0	12.0	18.0	10.3	15.5	9.50	14.3	
P_{ns} , kips	507	761	363	546	174	262	127	192	81.1	122	63.0	94.7	
P_{ns} , kips	164	246	123	185	87.8	132	58.7	88.2	45.9	68.9	35.4	53.2	
L_{p1} , ft	7.49		7.42		7.35		7.21		7.17		7.18		
L_{r1} , ft	47.6		41.6		35.2		29.9		27.0		24.8		
A_g , in. ²	19.7		17.1		14.1		11.7		10.3		9.13		
I_x , in. ⁴	272		228		184		146		127		110		
I_y , in. ⁴	88.6		75.1		60.9		49.1		42.6		37.1		
r_x , in.	2.12		2.10		2.08		2.04		2.03		2.02		
r_y , in.	1.75		1.74		1.74		1.73		1.78		1.72		
$P_{ns} L_c^2/10^4$, k-in. ²	7790		6530		5270		4180		3630		3150		
$P_{ns} L_c^2/10^4$, k-in. ²	2540		2150		1740		1410		1220		1060		
ASD	LRFD		Note: Heavy lines indicates L_c/r_y equal to or greater than 200.										
$\Omega_c = 1.67$	$\phi_c = 0.90$												

AISC Critical Stress Table

for previous example $Kl/r_y = 118.2$

$W8 \times 35$
 $F_y = 50 \text{ ksi}$
 $E = 29,000 \text{ ksi}$
 $L = 25' \text{ (NO BRACING)}$

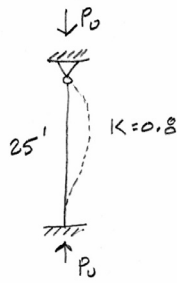

Slenderness $y-y$

$$\frac{Kl_y}{r_y} = \frac{0.8(25)}{2.03} = 118.2$$

TO FIND CAPACITY:

$$\phi F_{cr} = 16.2 \text{ ksi}$$

$$\phi P_n = P_U = \phi F_{cr} A_g$$

$$P_U = 16.2(10.3) = 166.8 \text{ k}$$

Table 4-22 (continued)
Available Critical Stress for
Compression Members

$\frac{KL}{r}$	$F_y = 35 \text{ ksi}$		$F_y = 36 \text{ ksi}$		$F_y = 42 \text{ ksi}$		$F_y = 46 \text{ ksi}$		$F_y = 50 \text{ ksi}$					
	F_{cr}/Ω_c	$\phi_c F_{cr}$	F_{cr}/Ω_c	$\phi_c F_{cr}$	F_{cr}/Ω_c	$\phi_c F_{cr}$	F_{cr}/Ω_c	$\phi_c F_{cr}$	F_{cr}/Ω_c	$\phi_c F_{cr}$				
	ASD	LRFD	ASD	LRFD	ASD	LRFD	ASD	LRFD	ASD	LRFD				
81	15.0	22.5	81	15.3	22.9	81	16.8	25.3	81	17.7	26.6	81	18.5	27.9
82	14.9	22.3	82	15.1	22.7	82	16.6	25.0	82	17.5	26.3	82	18.3	27.5
83	14.7	22.1	83	15.0	22.5	83	16.5	24.8	83	17.3	26.0	83	18.1	27.2
84	14.6	22.0	84	14.9	22.3	84	16.3	24.5	84	17.1	25.8	84	17.9	26.9
85	14.5	21.8	85	14.7	22.1	85	16.1	24.3	85	16.9	25.5	85	17.7	26.5
86	14.4	21.6	86	14.6	22.0	86	16.0	24.0	86	16.7	25.2	86	17.4	26.2
87	14.2	21.4	87	14.5	21.8	87	15.8	23.7	87	16.6	24.9	87	17.2	25.9
88	14.1	21.2	88	14.3	21.6	88	15.6	23.5	88	16.4	24.6	88	17.0	25.6
89	14.0	21.0	89	14.2	21.4	89	15.5	23.2	89	16.2	24.3	89	16.8	25.2
90	13.8	20.8	90	14.1	21.2	90	15.3	23.0	90	16.0	24.0	90	16.6	24.9
91	13.7	20.6	91	13.9	21.0	91	15.1	22.7	91	15.8	23.7	91	16.3	24.6
92	13.6	20.4	92	13.8	20.8	92	15.0	22.5	92	15.6	23.4	92	16.1	24.2
93	13.5	20.2	93	13.7	20.5	93	14.8	22.2	93	15.4	23.1	93	15.9	23.9
94	13.3	20.0	94	13.5	20.3	94	14.6	22.0	94	15.2	22.8	94	15.7	23.6
95	13.2	19.9	95	13.4	20.1	95	14.4	21.7	95	15.0	22.6	95	15.5	23.3
96	13.1	19.7	96	13.3	19.9	96	14.3	21.5	96	14.8	22.3	96	15.3	22.9
97	13.0	19.5	97	13.1	19.7	97	14.1	21.2	97	14.6	22.0	97	15.0	22.6
98	12.8	19.3	98	13.0	19.5	98	13.9	21.0	98	14.4	21.7	98	14.8	22.3
99	12.7	19.1	99	12.9	19.3	99	13.8	20.7	99	14.2	21.4	99	14.6	22.0
100	12.6	18.9	100	12.7	19.1	100	13.6	20.5	100	14.1	21.1	100	14.4	21.7
101	12.4	18.7	101	12.6	18.9	101	13.4	20.2	101	13.9	20.8	101	14.2	21.3
102	12.3	18.5	102	12.5	18.7	102	13.3	20.0	102	13.7	20.6	102	14.0	21.0
103	12.2	18.3	103	12.3	18.5	103	13.1	19.7	103	13.5	20.3	103	13.8	20.7
104	12.1	18.1	104	12.2	18.3	104	12.9	19.5	104	13.3	20.0	104	13.6	20.4
105	11.9	17.9	105	12.1	18.1	105	12.8	19.2	105	13.1	19.7	105	13.4	20.1
106	11.8	17.7	106	11.9	17.9	106	12.6	19.0	106	12.9	19.4	106	13.2	19.8
107	11.7	17.5	107	11.8	17.7	107	12.4	18.7	107	12.8	19.2	107	13.0	19.5
108	11.5	17.3	108	11.7	17.5	108	12.3	18.5	108	12.6	18.9	108	12.8	19.2
109	11.4	17.2	109	11.5	17.3	109	12.1	18.2	109	12.4	18.6	109	12.6	18.9
110	11.3	17.0	110	11.4	17.1	110	12.0	18.0	110	12.2	18.3	110	12.4	18.6
111	11.2	16.8	111	11.3	16.9	111	11.8	17.7	111	12.0	18.1	111	12.2	18.3
112	11.0	16.6	112	11.1	16.7	112	11.6	17.5	112	11.8	17.8	112	12.0	18.0
113	10.9	16.4	113	11.0	16.5	113	11.5	17.3	113	11.7	17.5	113	11.8	17.7
114	10.8	16.2	114	10.9	16.3	114	11.3	17.0	114	11.5	17.3	114	11.6	17.4
115	10.7	16.0	115	10.7	16.2	115	11.2	16.8	115	11.3	17.0	115	11.4	17.1
116	10.5	15.8	116	10.6	16.0	116	11.0	16.5	116	11.1	16.7	116	11.2	16.8
117	10.4	15.6	117	10.5	15.8	117	10.8	16.3	117	11.0	16.5	117	11.0	16.5
118	10.3	15.5	118	10.4	15.6	118	10.7	16.1	118	10.8	16.2	118	10.8	16.2
119	10.2	15.3	119	10.2	15.4	119	10.5	15.8	119	10.6	16.0	119	10.6	16.0
120	10.0	15.1	120	10.1	15.2	120	10.4	15.6	120	10.4	15.7	120	10.4	15.7

ASD LRFD
 $\Omega_c = 1.67$ $\phi_c = 0.90$

Steel Connections

Methods of Connections

Bolted



Welded



Steel Connections

Shop vs. Field Connections

Shop Connections:

- Welding preferably performed in the shop as opposed to the field due to controlled environment
- Members can be positioned for more economical welding (welding upside down is difficult)
- Welding may have an equipment advantage in the shop
- Shops use both welding and bolting



Field Connections:

- Bolting easily performed in the field and generally preferred when possible
- Bolting provides a method to erect the members and release the crane hook quickly



Steel Connections

Failure modes – Limit States

- Fasteners (bolts or welds)
 - shear
 - tension
 - bearing
- Connecting elements (plates or tees)
 - tension
 - block shear
 - tear out
- Supporting or supported members

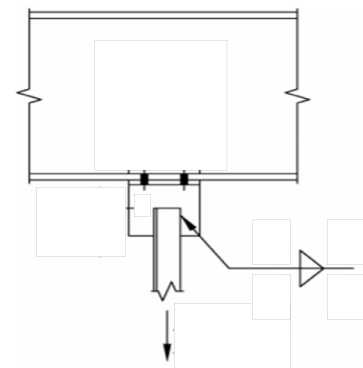
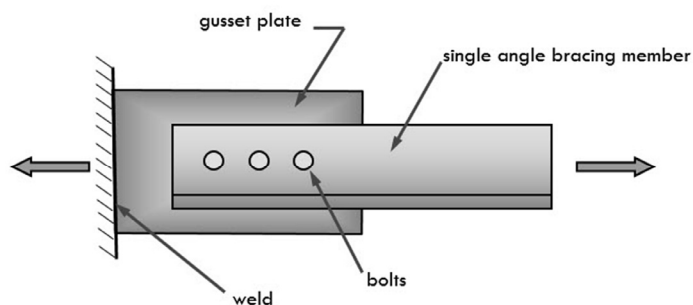

Tension Connection: Example Angle – Bolts – Gusset Plate

Load Path

Angle → Bolts → Gusset plate → Weld → Support

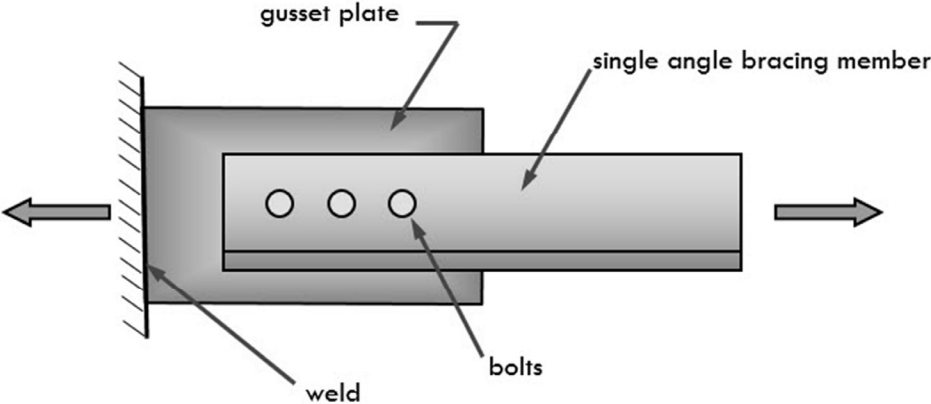

Tension Connection – Angle Failure example

- 1. Tensile Yielding
- 2. Tensile Rupture
- 3. Block Shear
- 4. Bearing and Tearout at Bolt Holes
- 5. Bolt Shear
- 6. Bearing and Tearout at Bolt Holes
- 7. Block Shear
- 8. Tensile Rupture
- 9. Tensile Yielding
- 10. Tension Rupture in Weld

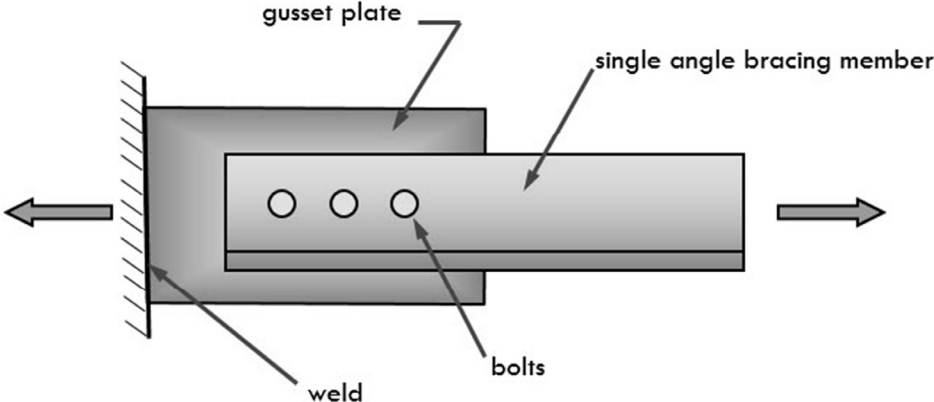

Tension Connection – Angle Failure

1. Tensile Yielding

- at gross section $R_n = F_y A_g \quad \phi = 0.9$
- F_y = minimum yield stress, ksi
- A_g = gross area of member, in²

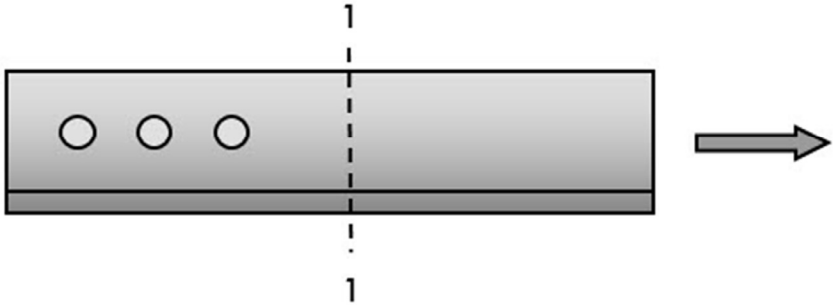

Tension Connection – Angle Failure

2. Tensile Rupture

Flat Bar

- $R_n = F_u A_e \quad \phi = 0.75$
- F_u = minimum tensile strength, ksi
- A_e = effective net area, in²

Section (not flat)

- $A_e = A_n U$
- A_n = net area
- U = shear lag factor (Table D3.1)

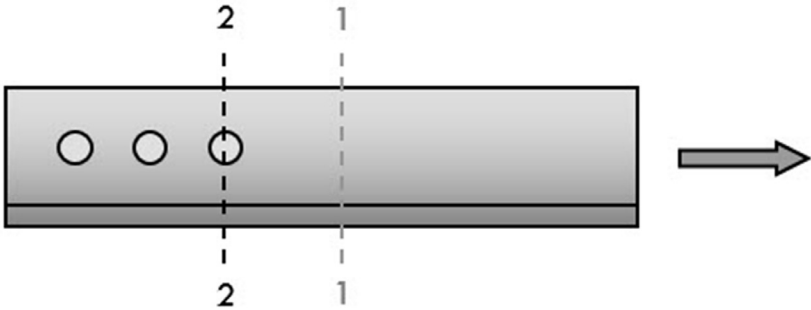
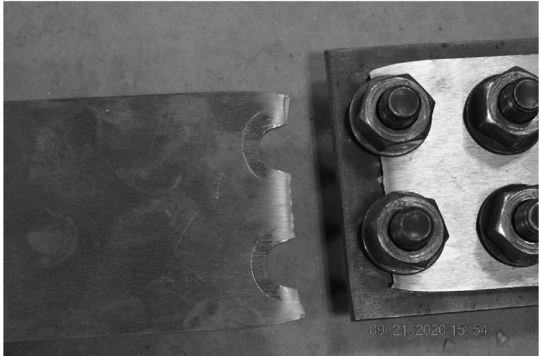

Tension Connection

Angle Failure

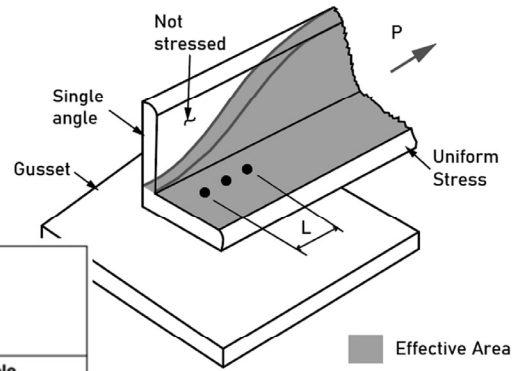

Case	Description of Element	Shear Lag Factor, U	Example
1	All tension members where the tension load is transmitted directly to each of the cross-sectional elements by fasteners or welds (except as in Cases 4, 5 and 6).	$U = 1.0$	—
2	All tension members, except HSS, where the tension load is transmitted to some but not all of the cross-sectional elements by fasteners or by longitudinal welds in combination with transverse welds. Alternatively, Case 7 is permitted for W, M, S and HP shapes. (For angles, Case 8 is permitted to be used.)	$U = 1 - \frac{\bar{x}}{l}$	
3	All tension members where the tension load is transmitted only by transverse welds to some but not all of the cross-sectional elements.	$U = 1.0$ and $A_n = \text{area of the directly connected elements}$	—
4 ^(a)	Plates, angles, channels with welds at heels, tees, and W-shapes with connected elements, where the tension load is transmitted by longitudinal welds only. See Case 2 for definition of \bar{x} .	$U = \frac{3l^2}{3l^2 + w^2} \left(1 - \frac{\bar{x}}{l} \right)$	
5	Round HSS with a single concentric gusset plate through slots in the HSS.	$l \geq 1.3D, U = 1.0$ $D \leq l < 1.3D, U = 1 - \frac{\bar{x}}{l}$ $\bar{x} = \frac{D}{\pi}$	

University of Michigan, TCAUP

Structures II

Slide 13 of 33

Tension Connection – Angle Failure

3. Block Shear

- $R_n = 0.60 F_u A_{nv} + U_{bs} F_u A_{nt}$ $\phi = 0.75$
- A_{nv} = net area in shear
- A_{nt} = net area in tension
- $U_{bs} = 1.0$ (uniform stress) $U_{bs} = 0.5$ (non-uniform stress)

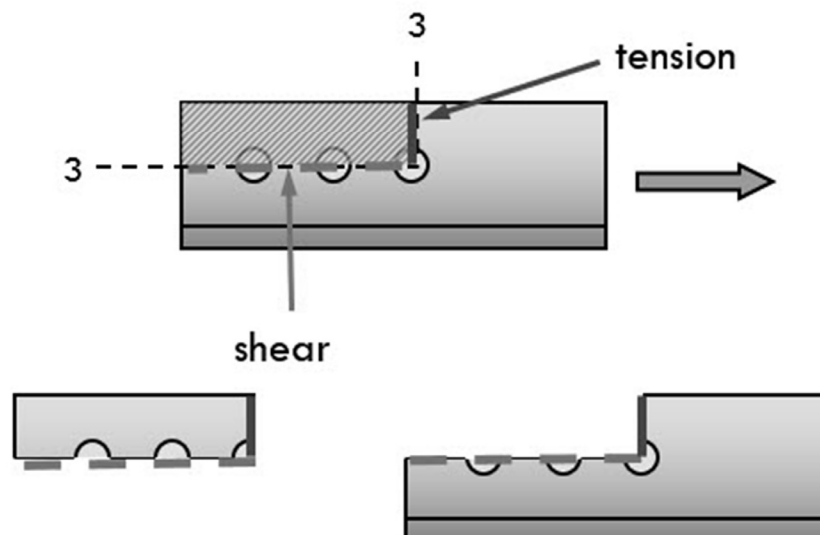

University of Michigan, TCAUP

Structures II

Slide 14 of 33

Tension Connection

Block Shear Example

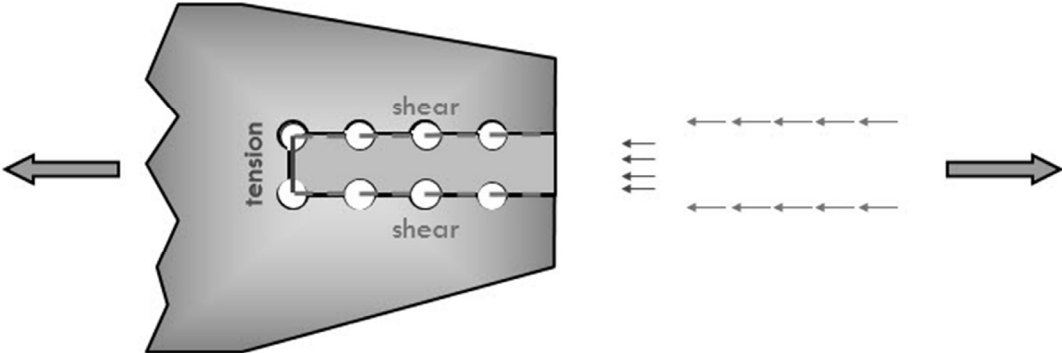

Tension Connection - Bolt Failure

4. Bearing and Tearout at Bolt Holes

- **Bearing:** deformation of material at the loaded edge of the bolt holes
- **Tearout:** block shear rupture between bolts or at the edge due to bearing

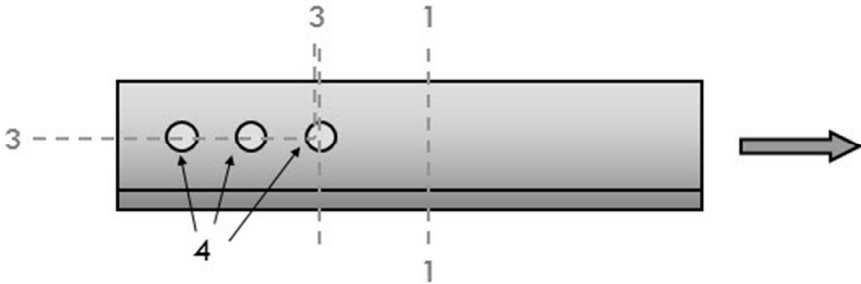
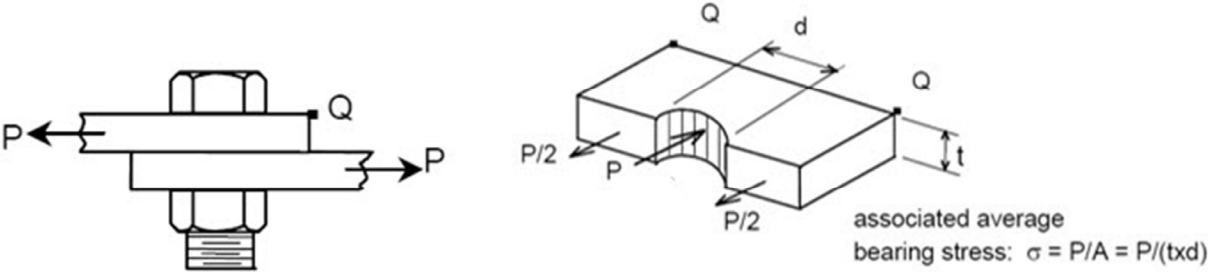

Tension Connection - Bolt Failure

4. Bearing and Tearout at Bolt Holes

- **Bearing:** deformation of material at the loaded edge of the bolt holes
- **Tearout:** block shear rupture between bolts or at the edge due to bearing

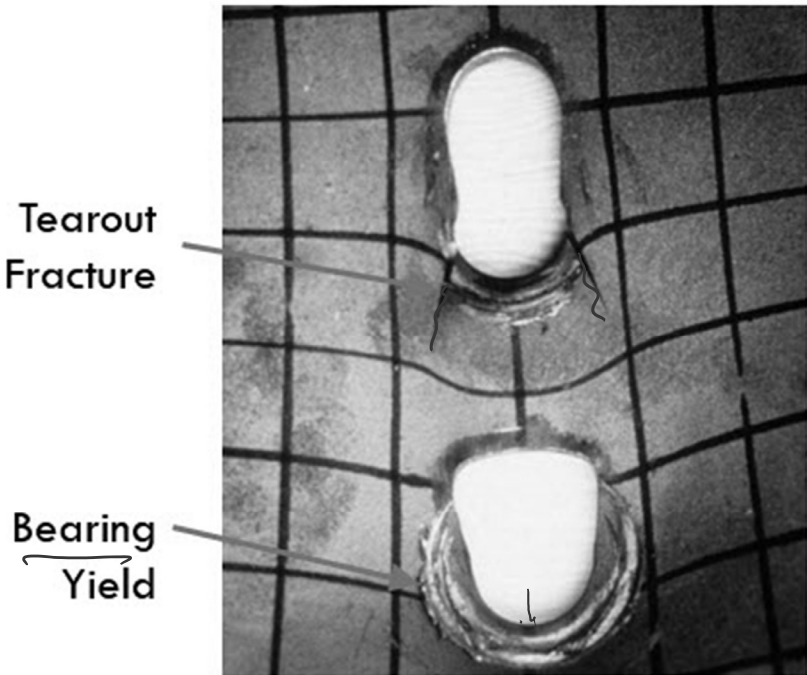

Tension Connection - Bolt Failure

5. Bolt Shear

- Shear failure of the bolts along the shear plane (interface)

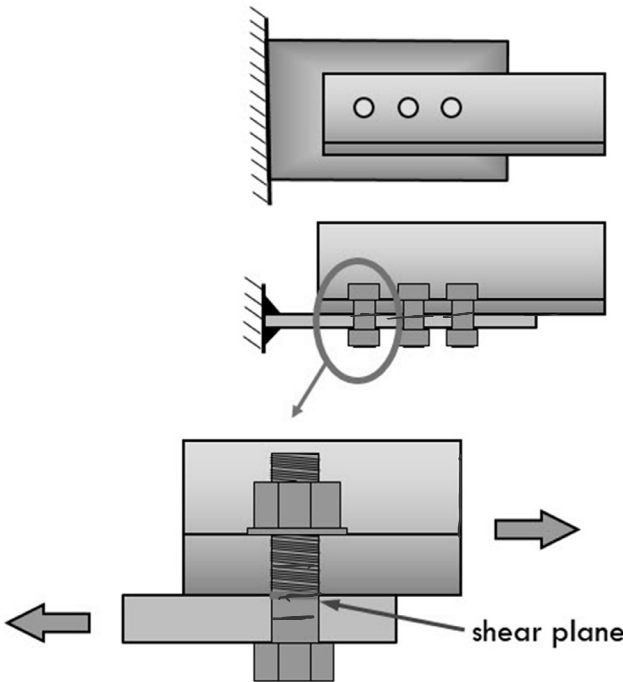

Tension Connection - Bolt Failure

5. Bolt Shear

- Shear failure of the bolts along the shear plane (interface)
- $R_n = F_n A_b \quad \phi = 0.75$
- F_n = nominal shear stress, F_{nv} (or tensile stress F_{nt})
- A_b = nominal bolt area (threaded or unthreaded)

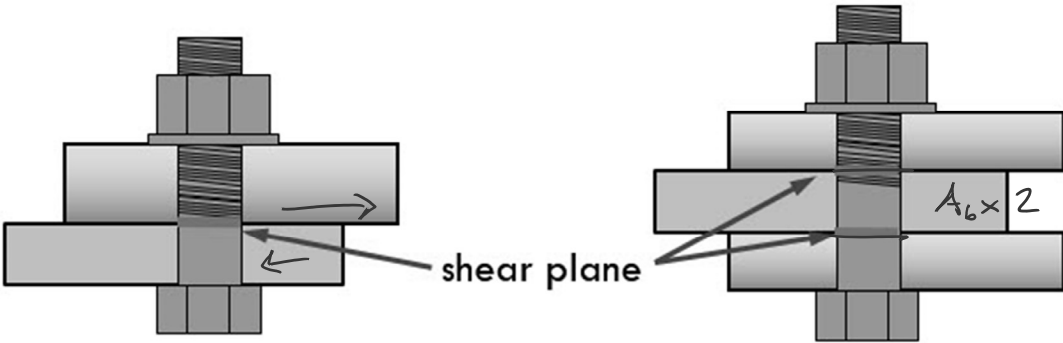

2 plies of material
(1 shear plane = Single Shear)

3 plies of material
(2 shear planes = Double Shear)

Tension Connection - Bolt Failure

5. Bolt Shear

- Shear failure of the bolts along the shear plane (interface)
- $R_n = F_n A_b \quad \phi = 0.75$
- F_n = nominal shear stress, F_{nv} (or tensile stress F_{nt})
- A_b = nominal bolt area (threaded or unthreaded)

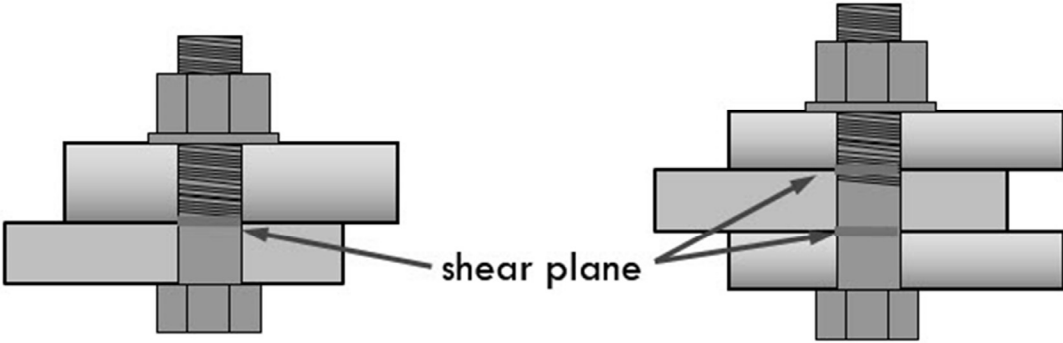

2 plies of material
(1 shear plane = Single Shear)

3 plies of material
(2 shear planes = Double Shear)

Tension Connection – Gusset Plate Failure

6. Bearing and Tearout at Bolt Holes

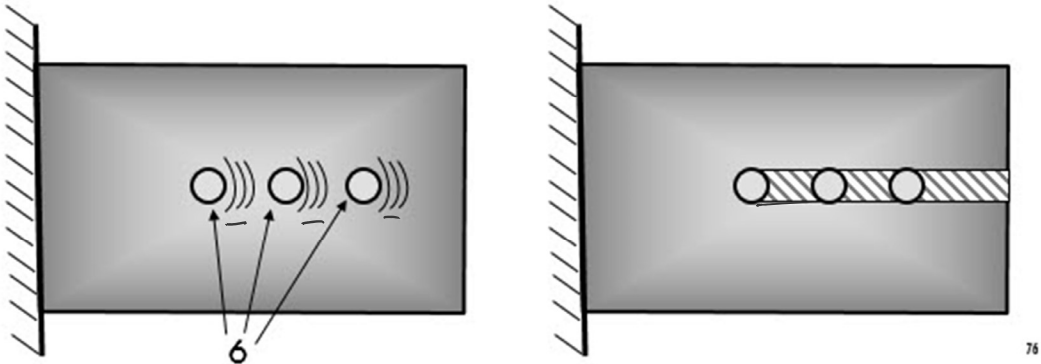

Tension Connection – Gusset Plate Failure

7. Block Shear

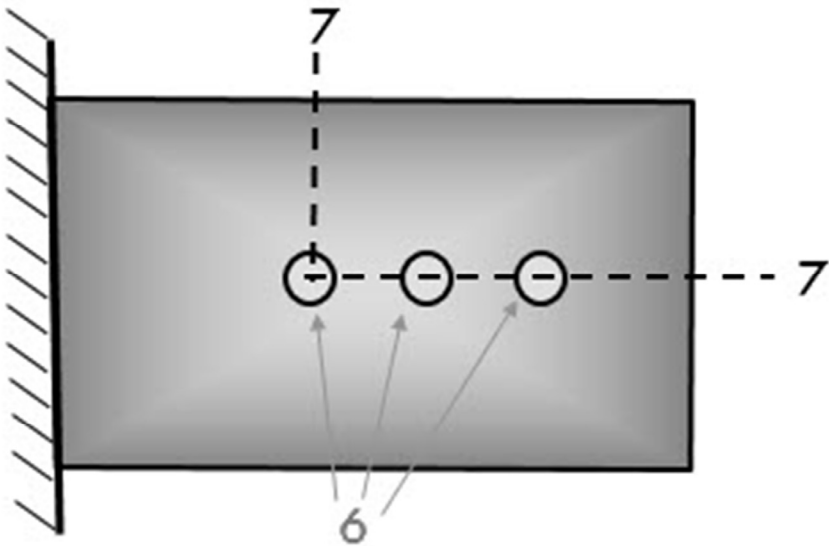

Tension Connection – Gusset Plate Failure

8. Tensile Rupture

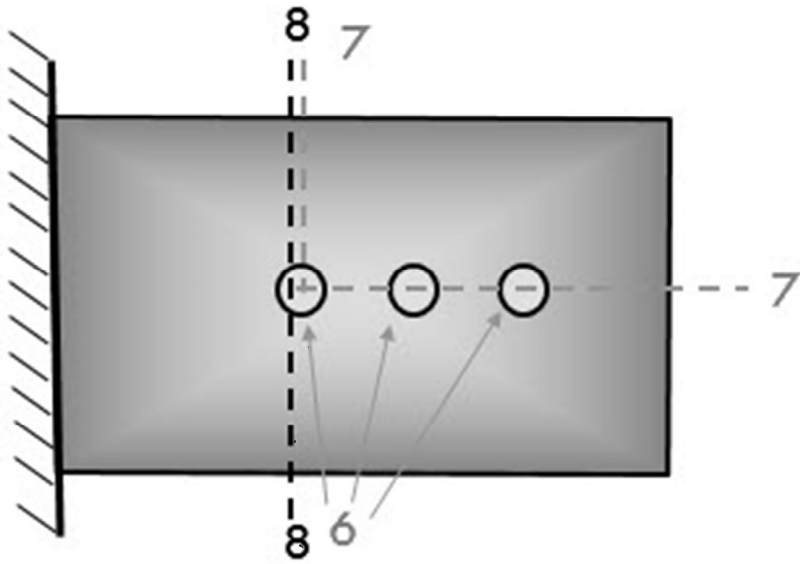

Tension Connection – Gusset Plate Failure

9. Tensile Yielding

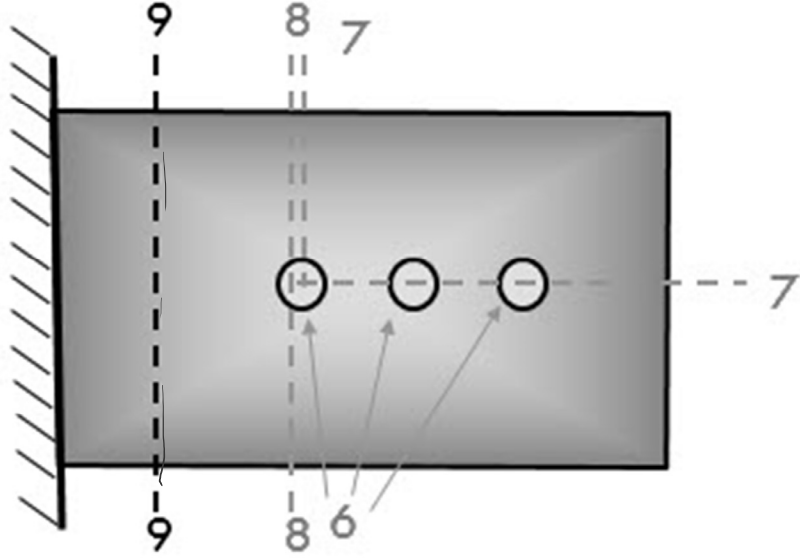

Tension Connection – Gusset Plate Failure

10. Tension Rupture in Weld

- Shear failure on the effective throat of the weld

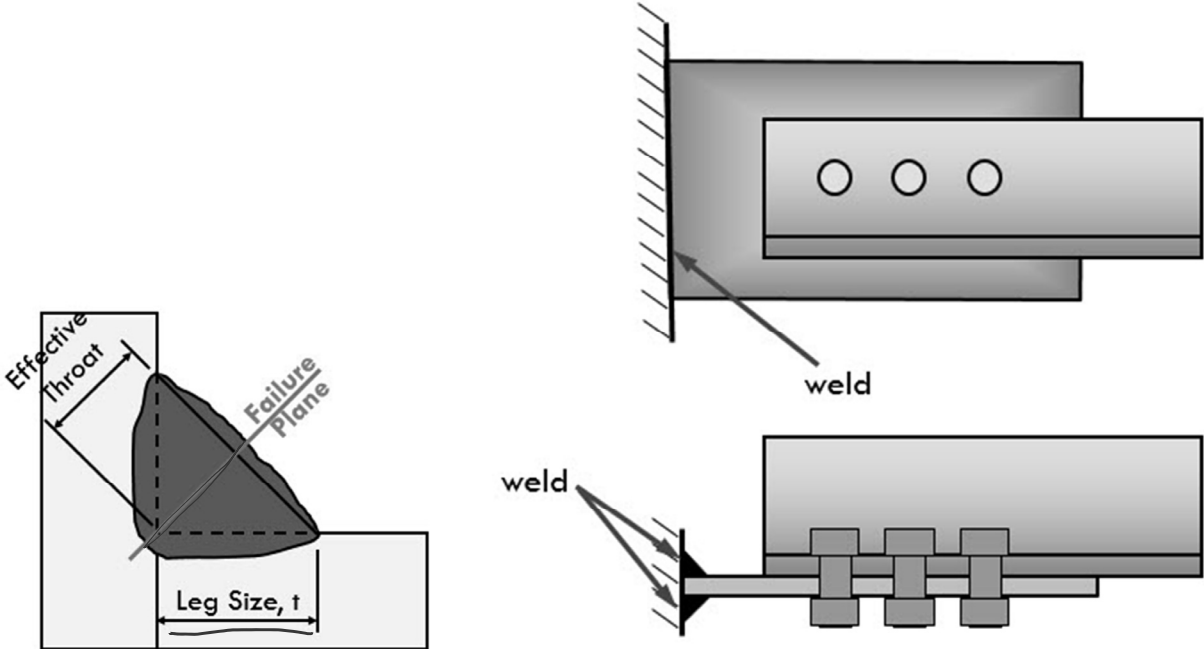

Steel Frame Construction



University of Michigan – North Quad

Steel Frame Construction

Messe Leipzig – 1996

Congress Centre – Gerkan, Marg und Partner

Glass Hall – Ian Ritchie Architects

Tower - Schlaich, Bergermann und Partner



Messe Leipzig - Glass Hall - Ian Ritchie Architects

University of Michigan, TCAUP

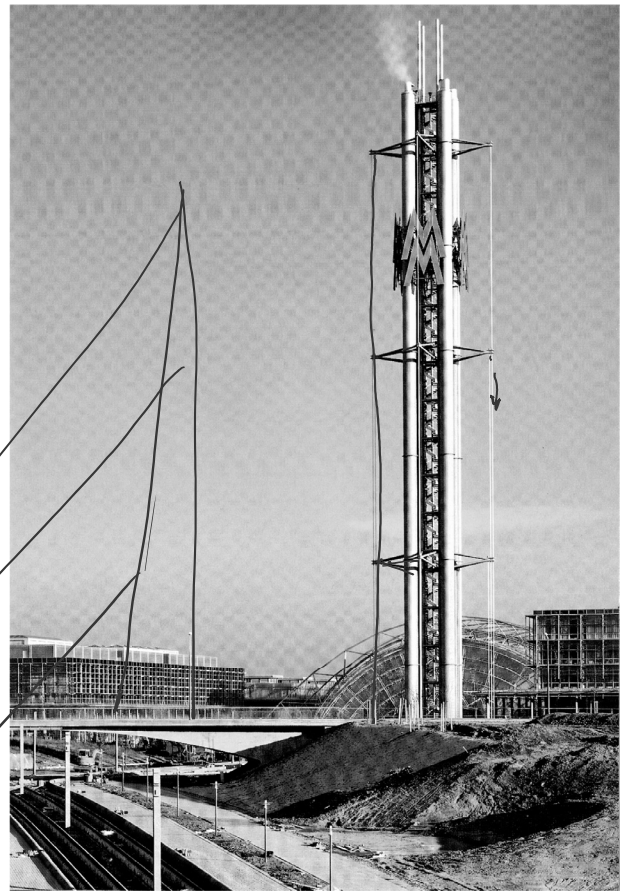

Messe Leipzig – Cable braced tower. Jörg Schlaich

Structures II

Slide 27 of 33

Steel Frame Construction



Messe Leipzig Glass Hall - Ian Ritchie Architects

University of Michigan, TCAUP

Structures II

Slide 28 of 33

Steel Frame Construction



Messe Leipzig Glass Hall - Ian Ritchie Architects

Branching Columns (tree columns) Frei Otto

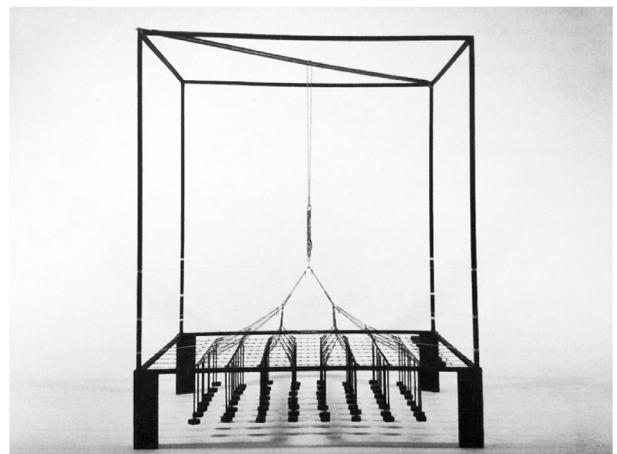
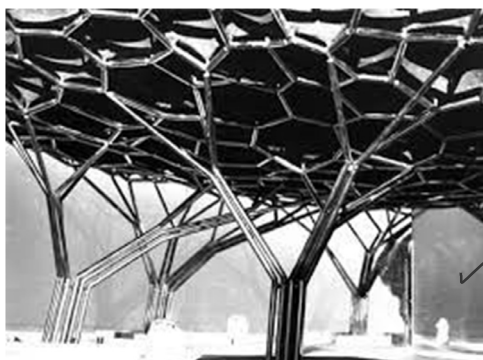
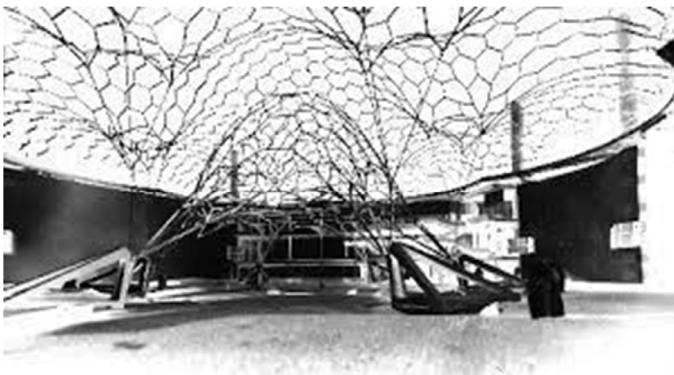

Branching Columns (tree columns)



bridge in Pragsattel, Stuttgart, 1992
Schlaich, Bergemann und Partner

Branching Columns (tree columns)



Stuttgart Airport Terminal,
Gerkan, Marg und Partner
Schlaich, Bergemann und Partner