

Concrete Columns (ACI 318)

- Types of columns
- Tied columns
- Spiral columns
- Interaction diagrams
- 3d printed forms

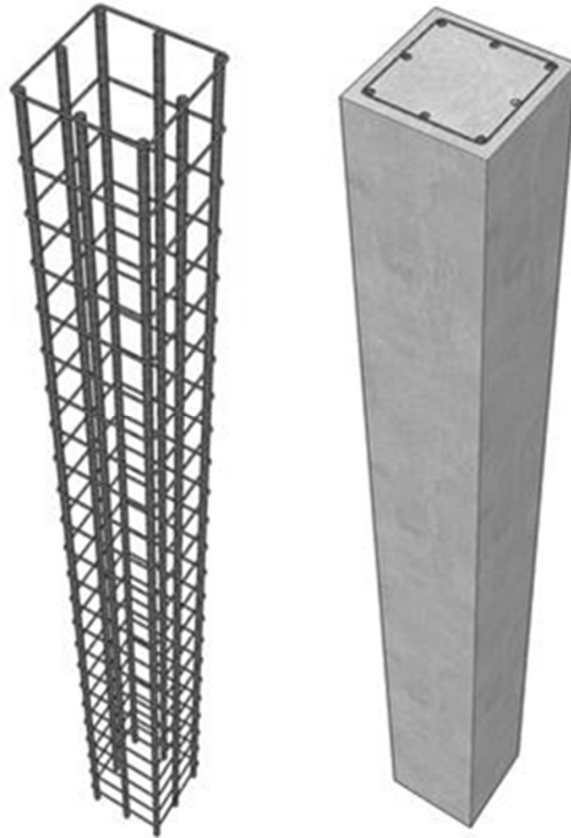

Compression Members

- **Pedestals** are compression members with an aspect less than or equal to 3:1. They can be used without reinforcing.
- **Columns** are any more slender members which carry primarily axial compressive loads.
- Columns always require reinforcing
ACI 318-19 section 10.6.1
- Minimum reinforcing to insure ductile failure:
1% i.e. $A_s/A_g \geq 0.01$
- Maximum reinforcing to prevent blockage:
8% i.e. $A_s/A_g \geq 0.08$
in practice 4% is better.

PEDESTAL

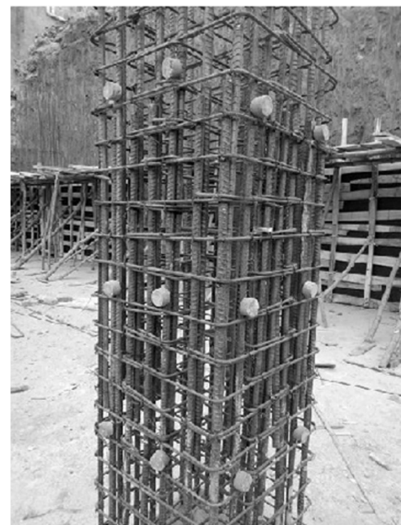
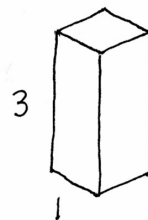

Types of Columns

There are 3 types of columns based on how they are reinforced:

1. tied column (a)
2. spiral column (b)
3. composite column (c & d)

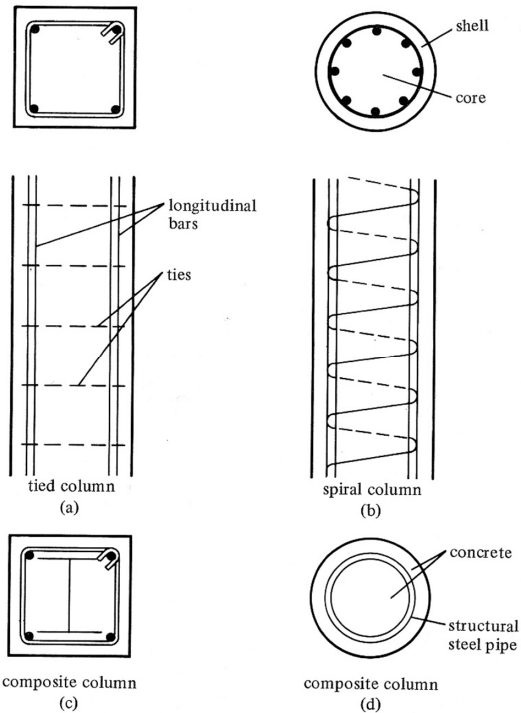

Column Reinforcing Tied Columns

The ties restrain the expansion of the core concrete and the outward buckling of the longitudinal bars.

Longitudinal bars:

- minimum for square columns is 4.
- minimum for round columns is 6.
- maximum spacing is 6"

Ties:

no less than #3 with #10 or less longitudinal steel.

no less than #4 with #11 and greater longitudinal steel.

tie spacing is the least of:

- 16 x longitudinal bar diameter
- 48 x tie diameter
- least width column

crossties brace alternate longitudinal bars or bars > 6" o.c.

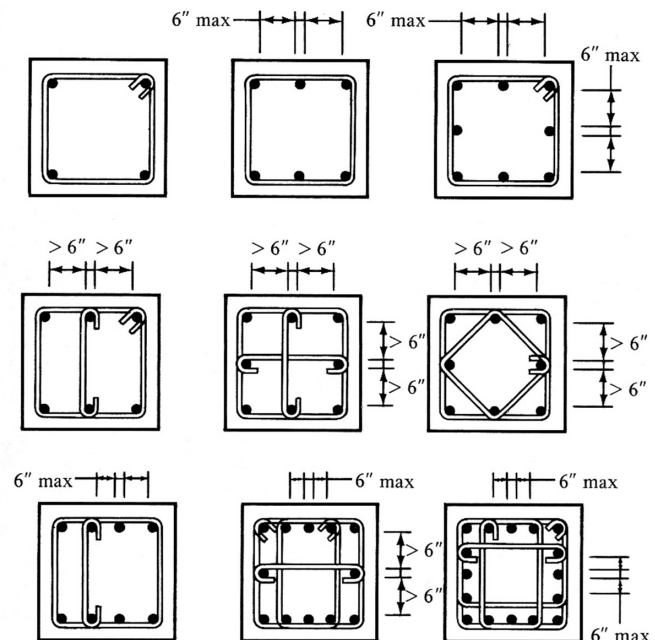

Figure 8.3 Typical Tie Arrangements

Column Reinforcing

Spiral Columns

Clear spacing (the pitch, s) should be between 1" and 3"

spiral should be continuous or spliced
must be welded or overlapped.

spacers (vertical bars with hooks) are used to hold spirals in place during casting.

Spiral columns are more ductile in failure and stronger than tied columns (by about 5%)

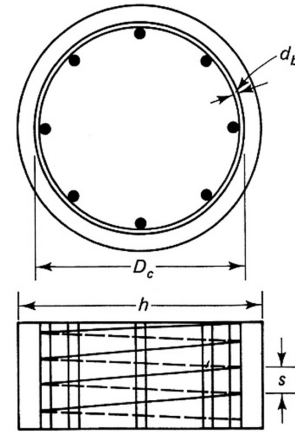

$$A_c = \frac{\pi D_c^2}{4}$$
$$A_g = \frac{\pi h^2}{4}$$



Column Design Considerations

High strength concrete is more effective than in beams.

Because steel is more expensive, it is better to increase column size and reduce steel needed.

Tied columns (particularly rectangular) are more economical than spiral.

But spiral columns with high strength concrete reduce column size.

Larger bar sizes reduce congestion when casting. Bars can also be bundled.

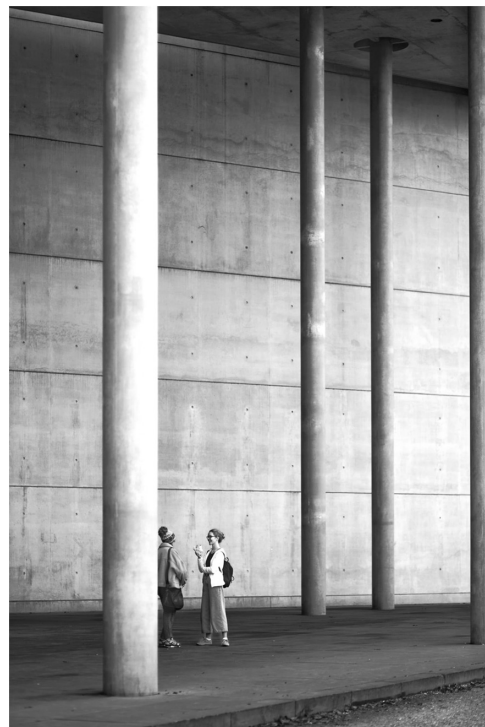

Column Modes of Failure

Stress distribution between steel and concrete varies under load and time, but ultimate failure is more predictable.

For design, failure is defined as the spalling of the cover concrete.

Even with the cover cracked the column will continue to carry load.

Spiral columns are tougher than tied

A column is a more critical member. It supports a greater area. Therefore the Φ factor is lower.

- $\Phi = 0.65$ for tied columns
- $\Phi = 0.75$ for spiral columns

Also: columns are more difficult to cast, and concrete carries more of the load than in beams



Ultimate Strength – (ACI 318 - 2014)

Reduced Nominal Strength \geq Factored Load Effects

$$\Phi S_n \geq U$$

γ **Factored Loads** (see ACSE 7)

- 1) 1.4D
- 2) 1.2D + 1.6L + 0.5(Lr or S or R)
- 3) 1.2D + 1.6(Lr or S or R) + (1.0L or 0.5W)
- 4) 1.2D + 1.0W + 1.0L + 0.5(Lr or S or R)
- 5) 1.2D + 1.0E + 1.0L + 0.2S
- 6) 0.9D + 1.0W
- 7) 0.9D + 1.0E

- D = service dead loads
- L = service live load
- Lr = service roof live load
- S = snow loads
- W = wind loads
- R = rainwater loads
- E = earthquake loads

Strength Reduction Factors, Φ

Mn	Flexural ($\epsilon > 0.005$)	0.90
Vn	Shear	0.75
Pn	Compression (spiral)	0.75
Pn	Compression (other)	0.65
Bn	Bearing	0.65
Tn	Torsion	0.75
Nn	Tension	0.90
Combined stress		0.65 to 0.90

ACI 318 21.2.2

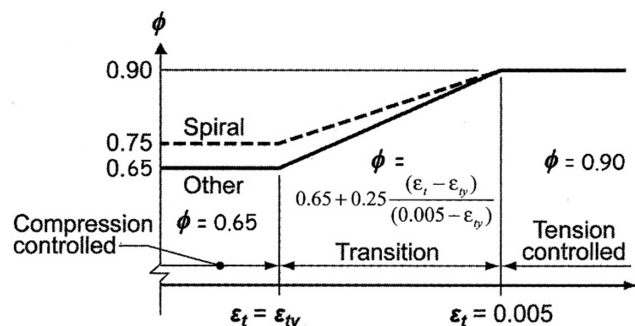

Axial Strength Calculation

P_o is the nominal axial strength with no eccentricity.

$P_{n,max}$ is P_o with a factor for minimum moment

For spiral and composite columns:

$$P_u = \Phi P_n = \Phi 0.85 [0.85f'_c (A_g - A_s) + f_y A_s]$$

For tied columns:

$$P_u = \Phi P_n = \Phi 0.80 [0.85f'_c (A_g - A_s) + f_y A_s]$$

22.4.2 Maximum axial compressive strength

22.4.2.1 Nominal axial compressive strength P_n shall not exceed $P_{n,max}$ in accordance with Table 22.4.2.1, where P_o is calculated by Eq. (22.4.2.2) for nonprestressed members and composite steel and concrete members, and by Eq. (22.4.2.3) for prestressed members.

Table 22.4.2.1—Maximum axial strength

Member	Transverse reinforcement	$P_{n,max}$	
Nonprestressed	Ties conforming to 22.4.2.4	$0.80P_o$	(a)
	Spirals conforming to 22.4.2.5	$0.85P_o$	(b)
Prestressed	Ties	$0.80P_o$	(c)
	Spirals	$0.85P_o$	(d)
Composite steel and concrete columns in accordance with Chapter 10	All	$0.85P_o$	(e)

22.4.2.2 For nonprestressed members and composite steel and concrete members, P_o shall be calculated by:

$$P_o = 0.85f'_c(A_g - A_{st}) + f_y A_{st} \quad (22.4.2.2)$$

where A_{st} is the total area of nonprestressed longitudinal reinforcement.

Axial Strength Design (no moment) Tied Column Procedure

- Find factored axial load P_u (apply λ factor for load case).
- Choose $\rho = A_s/A_g$ (0.01 min., 0.08 max.)
- Find concrete A_g based on ρ
 $A_s = \rho A_g$
 $P_u = \Phi P_n = \Phi 0.80 [0.85f'_c (A_g - A_s) + f_y A_s]$
- Choose column section based on A_g
- Find steel A_s based on concrete A_g .
Choose bar size and number
- Determine tie size.
for longitudinal bar $\leq \#10$ use #3 ties
for $> \#10$ or bundled bars use #4 ties
- Find tie spacing.
use the least of:
 - 48 x tie diameter
 - 16 x longitudinal steel diameter
 - least column dimension
- Check section dimensions.

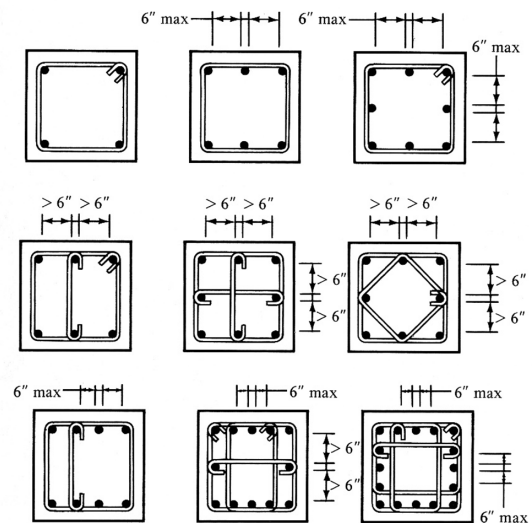

Figure 8.3 Typical Tie Arrangements

Axial Strength Design

(no moment)

Tied Column Example

Given: $P_{DL} = 200 \text{ k}$ $P_{LL} = 300 \text{ k}$
 $f'_c = 4000 \text{ psi}$ $f_y = 60,000 \text{ psi}$

Required: column size and reinforcement

1. Find factored axial load P_u (apply λ factor for load case).

$$P_u = 1.4(200) + 1.7(300) \\ = 280 + 510 = 790 \text{ k}$$

2. Choose $\rho = A_s/A_g$ (0.01 min., 0.08 max.)
assume $\rho = 0.02$ (good economically).

$$P_u = \phi 0.80 [0.85 f'_c (A_g - A_s) + f_y A_s] \\ \phi = 0.65 \text{ FOR TIED COLUMNS} \\ \text{FOR } \rho = 0.02 \quad A_s = \rho A_g = 0.02 A_g$$

3. Find concrete A_g based on ρ
 $P_u = \phi P_n = \phi 0.80 [0.85 f'_c (A_g - A_s) + f_y A_s]$

$$790 = 0.65(0.80) [0.85(4)(A_g - 0.02A_g) + 60(0.02A_g)] \\ 790 = 2.3566 A_g \\ A_g = 335.2 \text{ in}^2$$

4. Choose column section based on A_g

ASSUME SQUARE SECTION
 $\sqrt{335.2} = 18.31 \text{ in}$
ROUND UP TO WHOLE INCH, SAY $19" \times 19"$

Axial Strength Design

(no moment)

Tied Column Example

5. Find steel A_s based on concrete A_g .
Choose bar size and number

USE $A_g = 19 \times 19 = 361 \text{ in}^2$
FIND A_s

$$P_u = \phi 0.80 [0.85 f'_c (A_g - A_s) + f_y A_s]$$

$$790 = 0.65(0.80) [0.85(4)(361 - A_s) + 60A_s] \\ 790 = 638.2 + 29.43 A_s$$

$$A_s = 5.16 \text{ in}^2 \quad \text{USE 6 \#9 BARS} = 6.0 \text{ in}^2$$

Axial Strength Design

(no moment)

Tied Column Example

- Determine tie size.
for longitudinal bar $\leq \#10$ use #3 ties
for $> \#10$ or bundled bars use #4 ties
- Find tie spacing.
use the least of:
 - 48 x tie diameter
 - 16 x longitudinal steel diameter
 - least column dimension
- Check section dimensions.

TIE SIZE

$\#9 < \#10 \therefore$ USE $\#3$ TIES

TIE SPACING

- $48 \times \frac{3}{8} = 18'' \leftarrow$ USE SMALLEST
- $16 \times 1.128 = 18.05''$
- LEAST DIM. = $19''$

USE $18''$ TIE SPACING

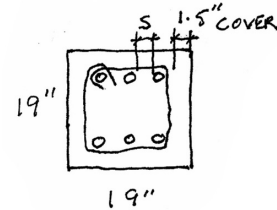

$$S = \frac{19'' - 2(1.5) - 3(\frac{1}{2} \#9) - 2(0.375)}{2}$$

$$S = \frac{11.866''}{2} = 5.93''$$

$5.93'' < 6'' \therefore$ NO CROSS TIES

Axial Strength Design

(no moment)

Spiral Column Procedure

- Find factored axial load P_u (apply λ factor for load case).
- Choose $\rho = A_s/A_g$ (0.01 min., 0.08 max.)
- Find concrete A_g based on ρ
 $P_u = \Phi P_n = \Phi 0.80 [0.85f'_c (A_g - A_s) + f_y A_s]$
 $\Phi = 0.75$
- Choose column diameter based on A_g
- Find concrete core area, $A_c = \frac{\pi D_c^2}{4}$
 $D_c =$ diameter of core, out to out of spiral
- Find $\rho_s \text{ min} = 0.45 (A_g/A_c - 1) f'_c/f_y$
 $\rho_s =$ ratio of volume of spiral steel to volume of concrete core
- Choose spiral bar size. Minimum = $3/8''$
- Determine spiral pitch, $1'' \leq s \leq 3''$

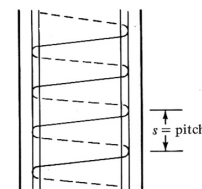
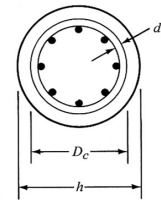

FIND PITCH s :

$$S = \frac{A_{s_s} (D_c - d_b)}{\rho_s D_c^2}$$

$D_c =$ DIAMETER OF A_c (FROM OUTER EDGE OF SPIRAL)
 $A_{s_s} =$ AREA OF SPIRAL STEEL
 $d_b =$ DIAMETER OF SPIRAL STEEL (BAR DIAMETER)

$1'' \leq s \leq 3''$
 IF $s < 1''$ CHOOSE SMALLER BAR
 IF $s > 3''$ CHOOSE LARGER BAR OR BIGGER COLUMN DIAMETER

Combined Axial + Flexure

Bending moments are almost always present due to columns being continuously cast with beams.

Solutions are normally found using interaction diagrams.

Axial force is on the vertical axis and the flexure moment is the horizontal

Each curve is for a different ρ

Graphs are for specific bar arrangements, f'_c and f_y

1. Choose section dimensions
2. Calculate K_n and R_n
3. Find ρ
4. Determine $A_s = \rho A_g$
5. Check bar spacing, A_g and ties.

Column Interaction Diagram

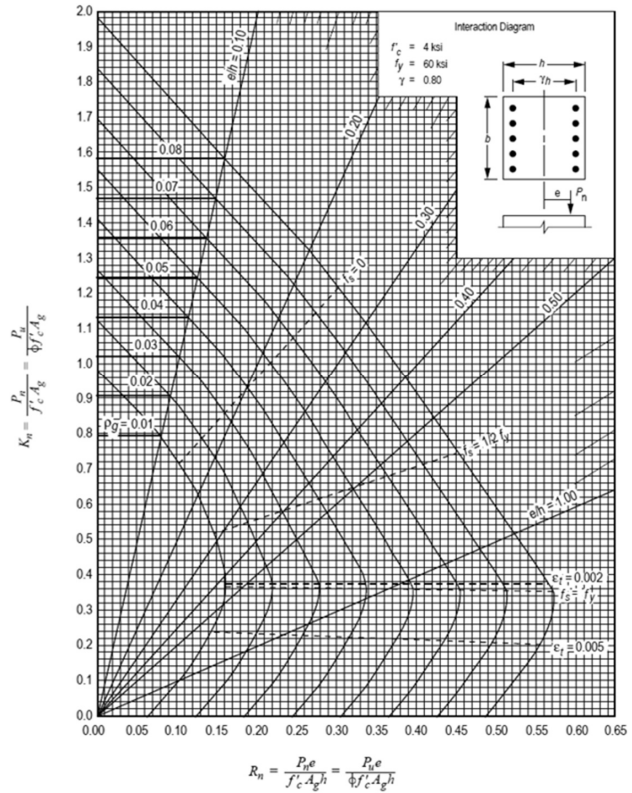

3D printed / robotic fabrication

difficult to integrate longitudinal steel.

could be used as forms for casting column

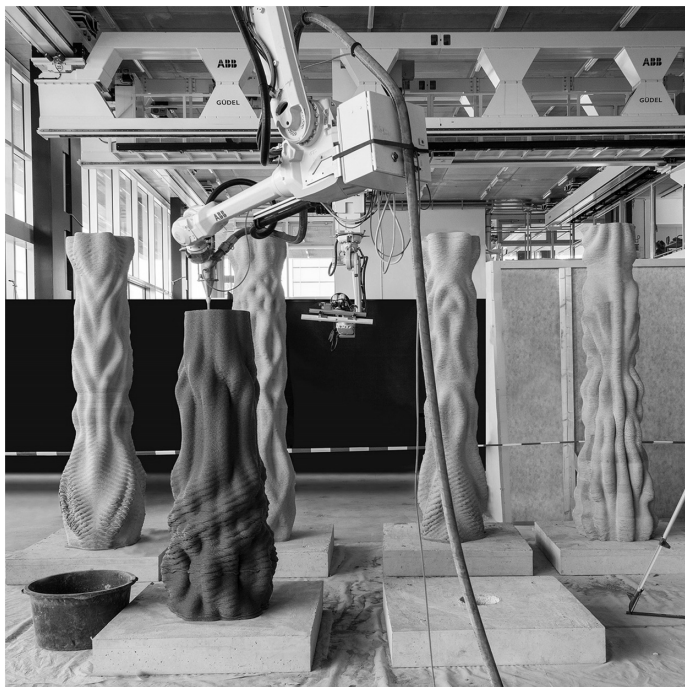

ETH, Zurich



Taubman College



Quinta da Boavista
SAMF Arquitectos