

Cross-Laminated Timber CLT

Kreuzlagenholz KLH

Material Properties
Structural Properties
Structural Design
Construction Details
Examples



Peter von Buelow

University of Michigan, TCAUP

Slide 1 of 42

Cross-Laminated Timber Characteristics

- large-scale solid wood panel
- prefabricated
- lightweight, yet very strong
- fast and easy to install
- low environmental impact
- superior acoustic, fire, seismic, and thermal performance

Highly advantageous alternative to conventional materials like concrete, masonry, or steel, especially in multi-family and commercial construction.



Fire Resistance of Timber

- Timber generally chars at 1"/hour
- Flat panels burn slower than edges
- Maintain strength in heat better than steel
- Allowed heights by IBC

Fully Protected	Type IV-A	270' ✓
Partially Protected	Type IV-B	180'
Exposed	Type IV-C	85'

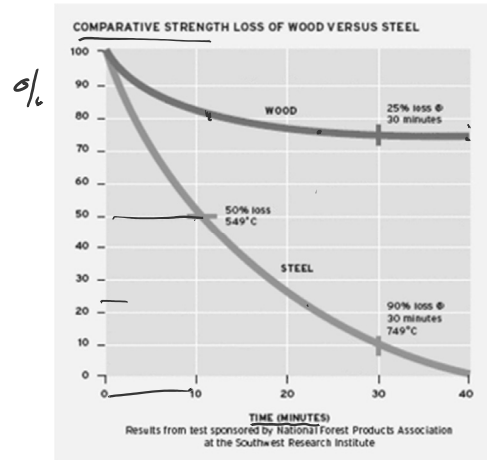
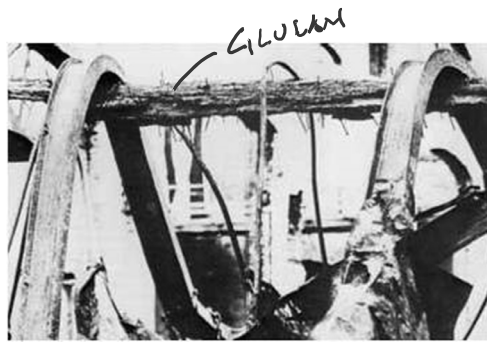

Cross-Laminated Timber Composition

- several layers of kiln-dried lumber boards
- stacked in alternating directions
- bonded with structural adhesives
- pressed to form a solid, straight, rectangular panel
- odd number of layers – usually 3 to 7
- may be sanded or prefinished



Cross-Laminated Timber Fabrication

- panels are cut to size
- pre-cut door and window openings
- can be CNC routed ✓
- panels are exceptionally stiff, strong, and stable
- structural load transfer on any side
- panels are typically 2 to 10 feet wide 18 ft. max.
- lengths up to 60 feet (98 ft. max.)
- thickness up to 20 inches

CNC

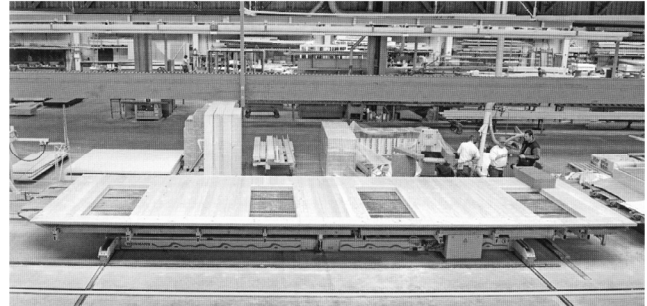

Cross-Laminated Timber Performance Standards

- American National Standard ANSI / APA PRG 320-2019
- APA certification by APA member mills.
- designed to assure manufacture in conformance with APA performance standards

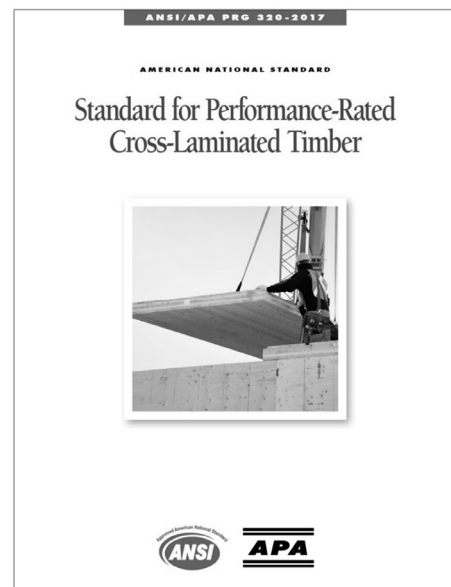

Cross-Laminated Timber

CHAPTER 1	Introduction to cross-laminated timber
CHAPTER 2	Cross-laminated timber manufacturing
CHAPTER 3	Structural design of cross-laminated timber elements
CHAPTER 4	Lateral design of cross-laminated timber buildings
CHAPTER 5	Connections in cross-laminated timber buildings
CHAPTER 6	Duration of load and creep factors for cross-laminated timber panels
CHAPTER 7	Vibration performance of cross-laminated timber floors
CHAPTER 8	Fire performance of cross-laminated timber assemblies
CHAPTER 9	Sound insulation of cross-laminated timber assemblies
CHAPTER 10	Building enclosure design for cross-laminated timber construction
CHAPTER 11	Environmental performance of cross-laminated timber
CHAPTER 12	Lifting and handling of cross-laminated timber elements

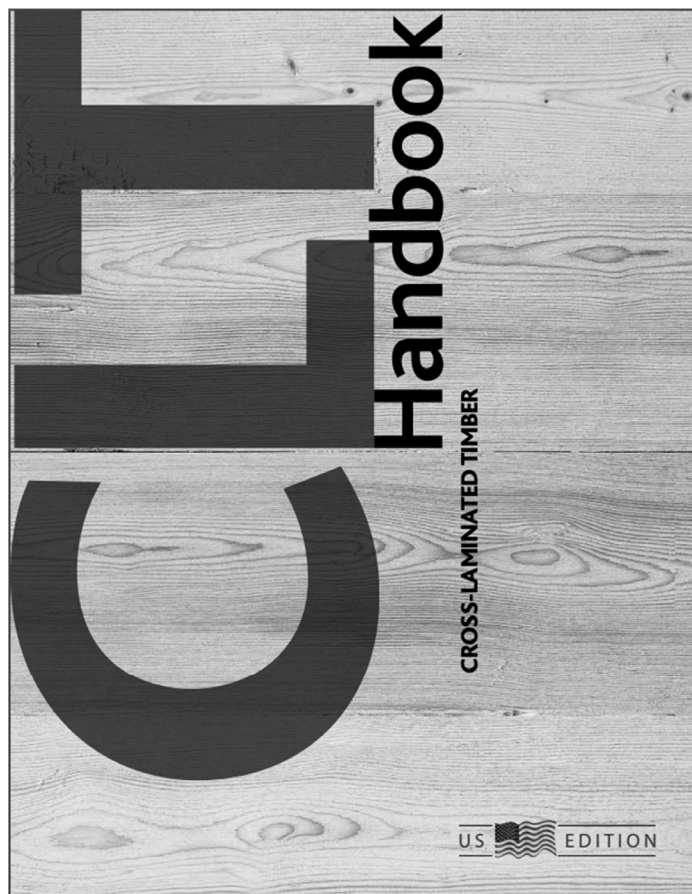

Cross-Laminated Timber Structural Properties

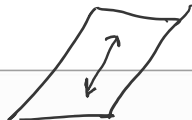

TABLE A1. ALLOWABLE DESIGN PROPERTIES^(a,b,c) FOR PRG 320 CLT (for use in the U.S.)

CLT Grades	Major Strength Direction						Minor Strength Direction					
	$F_{b,0}$ (psi)	E_0 (10^6 psi)	$F_{1,0}$ (psi)	$F_{c,0}$ (psi)	$F_{v,0}$ (psi)	$F_{s,0}$ (psi)	$F_{b,90}$ (psi)	E_{90} (10^6 psi)	$F_{1,90}$ (psi)	$F_{c,90}$ (psi)	$F_{v,90}$ (psi)	$F_{s,90}$ (psi)
E1	1,950	1.7	1,375	1,800	135	45	500	1.2	250	650	135	45
E2	1,650	1.5	1,020	1,700	180	60	525	1.4	325	775	180	60
E3	1,200	1.2	600	1,400	110	35	350	0.9	150	475	110	35
E4	1,950	1.7	1,375	1,800	175	55	575	1.4	325	825	175	55
V1	900	1.6	575	1,350	180	60	525	1.4	325	775	180	60
V2	875	1.4	450	1,150	135	45	500	1.2	250	650	135	45
V3	975	1.6	550	1,450	175	55	575	1.4	325	825	175	55

For SI: 1 psi = 0.006895 MPa

(a) See Section 4 for symbols.

(b) Tabulated values are allowable design values and not permitted to be increased for the lumber size adjustment factor in accordance with the NDS. The design values shall be used in conjunction with the section properties provided by the CLT manufacturer based on the actual layout used in manufacturing the CLT panel (see Table A2).

(c) Custom CLT grades that are not listed in this table shall be permitted in accordance with Section 7.2.1

Cross-Laminated Timber Adjustment Factors

CLT Handbook – Ch.3 Table 1

		ASD only	ASD and LRFD				LRFD only			
		Load Duration Factor ✓	Wet Service Factor ✗	Temperature Factor ✓	Beam Stability Factor	Column Stability Factor	Format Conversion Factor	Resistance Factor	Time Effect Factor	
							K_F	ϕ		
M	$F'_b S_{eff} = F_b S_{eff}$	X	C_D	C_M	C_t	C_L	-	2.54	0.85	λ
T	$F'_t A_{parallel} = F_t A_{parallel}$	X	C_D	C_M	C_t	-	-	2.70	0.80	λ
V	$F'_v (Ib/Q)_{eff} = F_v (Ib/Q)_{eff}$	X	C_D	C_M	C_t	-	-	2.88	0.75	λ
C	$F'_c A_{parallel} = F_c A_{parallel}$	X	C_D	C_M	C_t	-	C_P	2.40	0.90	λ
B	$F'_{c\perp} A = F_{c\perp} A$	X	-	C_M	C_t	-	-	1.67	0.90	-
	$EI'_{app} = EI_{app}$	X	-	C_M	C_t	-	-	-	-	-
	$EI'_{app-min} = EI_{app-min}$	X	-	C_M	C_t	-	-	1.76	0.85	-

Cross-Laminated Timber - Allowable Bending Capacity

TABLE A2. THE ALLOWABLE BENDING CAPACITIES^(a,b,c) FOR CLT LISTED IN TABLE A1 (FOR USE IN THE U.S.)

CLT Grade	CLT I (in.)	Lamination Thickness (in.) in CLT Layout								Major Strength Direction			Minor Strength Direction		
		=	⊥	=	⊥	=	⊥	=	⊥	M $F'_b S_{eff,0}$ (10 ⁶ lbf-ft)	$EI'_{eff,0}$ (10 ⁶ lbf-in. ² /ft)	V $GA'_{eff,0}$ (10 ⁶ lbf/ft)	$F'_b S_{eff,90}$ (10 ⁶ lbf-ft)	$EI'_{eff,90}$ (10 ⁶ lbf-in. ² /ft)	$GA'_{eff,90}$ (10 ⁶ lbf/ft)
E1	4 1/8	1 3/8	1 3/8	1 3/8	1 3/8					4,525	115	0.46	160	3.1	0.61
	6 7/8	1 3/8	1 3/8	1 3/8	1 3/8	1 3/8	1 3/8			10,400	440	0.92	1,370	81	1.2
	9 5/8	1 3/8	1 3/8	1 3/8	1 3/8	1 3/8	1 3/8	1 3/8	1 3/8	18,375	1,089	1.4	3,125	309	1.8
E2	4 1/8	1 3/8	1 3/8	1 3/8						3,825	102	0.53	165	3.6	0.56
	6 7/8	1 3/8	1 3/8	1 3/8	1 3/8	1 3/8	1 3/8			8,825	389	1.1	1,430	95	1.1
	9 5/8	1 3/8	1 3/8	1 3/8	1 3/8	1 3/8	1 3/8	1 3/8	1 3/8	15,600	963	1.6	3,275	360	1.7
E3	4 1/8	1 3/8	1 3/8	1 3/8						2,800	81	0.35	110	2.3	0.44
	6 7/8	1 3/8	1 3/8	1 3/8	1 3/8	1 3/8	1 3/8			6,400	311	0.69	955	61	0.87
	9 5/8	1 3/8	1 3/8	1 3/8	1 3/8	1 3/8	1 3/8	1 3/8	1 3/8	11,325	769	1.0	2,180	232	1.3
E4	4 1/8	1 3/8	1 3/8	1 3/8						4,525	115	0.53	180	3.6	0.63
	6 7/8	1 3/8	1 3/8	1 3/8	1 3/8	1 3/8	1 3/8			10,425	441	1.1	1,570	95	1.3
	9 5/8	1 3/8	1 3/8	1 3/8	1 3/8	1 3/8	1 3/8	1 3/8	1 3/8	18,400	1,090	1.6	3,575	360	1.9
V1	4 1/8	1 3/8	1 3/8	1 3/8						2,090	108	0.53	165	3.6	0.59
	6 7/8	1 3/8	1 3/8	1 3/8	1 3/8	1 3/8	1 3/8			4,800	415	1.1	1,430	95	1.2
	9 5/8	1 3/8	1 3/8	1 3/8	1 3/8	1 3/8	1 3/8	1 3/8	1 3/8	8,500	1,027	1.6	3,275	360	1.8
V2	4 1/8	1 3/8	1 3/8	1 3/8						2,030	95	0.46	160	3.1	0.52
	6 7/8	1 3/8	1 3/8	1 3/8	1 3/8	1 3/8	1 3/8			4,675	363	0.91	1,370	81	1.0
	9 5/8	1 3/8	1 3/8	1 3/8	1 3/8	1 3/8	1 3/8	1 3/8	1 3/8	8,275	898	1.4	3,125	309	1.6
V3	4 1/8	1 3/8	1 3/8	1 3/8						2,270	108	0.53	180	3.6	0.59
	6 7/8	1 3/8	1 3/8	1 3/8	1 3/8	1 3/8	1 3/8			5,200	415	1.1	1,570	95	1.2
	9 5/8	1 3/8	1 3/8	1 3/8	1 3/8	1 3/8	1 3/8	1 3/8	1 3/8	9,200	1,027	1.6	3,575	360	1.8

For SI: 1 in. = 25.4 mm; 1 ft = 304.8 mm; 1 lbf = 4.448 N

(a) See Section 4 for symbols.

(b) This table represents one of many possibilities that the CLT could be manufactured by varying lamination grades, thicknesses, orientations, and layer arrangements in the layout.

(c) Custom CLT grades that are not listed in this table shall be permitted in accordance with Section 7.2.1.

1.2 Load Duration Factor, C_D

The load duration factor is applicable only for ASD design methodology. This factor accounts for wood's greater strength over short durations. The load durations are assumed to be the same for CLT products as they are for other wood products and can be found in Table 2.3.2 of the NDS.

1.3 Wet Service Factor, C_M ✕

The wet service factor adjusts the strength properties of the wood in the absence of the assumed dry condition. Dry service conditions are defined for structural glued laminated timber as moisture content less than 16% in service, such as in most covered structures. At the time of manufacturing, PRG 320 requires that the moisture content of the laminations be no more than 15% and further states that the panels are only intended for use in dry service conditions. Contact the manufacturer if a wet service condition is expected.

1.4 Temperature Factor, C_t

The temperature factor adjusts the strength properties of the wood if it will see sustained elevated temperatures above 100°F. This adjustment should be considered for applications when frequent and sustained temperatures above 100°F will occur. Roof systems and other assemblies subject to diurnal temperature fluctuations from solar radiation are not applications that normally require adjustment for temperature (NDS Commentary). Section 2.3.3 of the NDS gives the adjustment factors, which depend on the material property being adjusted and whether it is a wet or dry service condition. It is assumed that these considerations are applicable to CLT as well.

Cross-Laminated Timber - Flexure

2.1.1 Bending Members: Flexure (Out-of-plane)

For out-of-plane loads, the beam stability factor should be 1.0. The volume factor is not applicable to CLT.

The simplified method has been adopted in the product standard PRG 320 and calculates the capacity by using an extreme fiber capacity approach. The effective section modulus is found by dividing the effective bending stiffness, found with Equation [24] of this Chapter, by the modulus of elasticity of the outer layer and half the thickness of the panel. In equation form, it is as follows:

$$S_{eff} = \frac{EI_{eff}}{E_1 \cdot \frac{h}{2}} \quad [1]$$

where:

- EI_{eff} = Effective bending stiffness
- E_1 = Modulus of elasticity of outermost layer
- h = Entire thickness of panel

The effective bending stiffness can be obtained using Equation [24]:

$$EI_{eff} = \sum_{i=1}^n E_i b_i \frac{h_i^3}{12} + \sum_{i=1}^n E_j A_i \cdot z_i^2$$

$\frac{bh^3}{12} + Ad^2$

The effective section modulus is then multiplied by allowable bending stress of the outermost layer and "the calculated moment capacities in the major strength direction are further multiplied by a factor of 0.85 for conservatism" (PRG 320-2011). Manufacturers will have already done this calculation to give the moment capacity of the member. For design, the induced bending moment must be less than the moment capacity. In equation form, it would appear as follows:

$$M_b \leq F_b' S_{eff} \quad [2]$$

M_b = Applied bending moment due to loads

$F_b' S_{eff}$ = Design bending strength of the panel provided by the manufacturer, calculated, or listed in the product standard PRG 320 and then multiplied by the applicable adjustment factors.

An example of the calculation of the bending moment capacity using the simplified method is given in Section 4.

2.1.3 Bending Members: Deflection (Out-of-plane)

One method to account for the shear deformation is to reduce the effective bending stiffness value, EI_{eff} , to an apparent EI . The derivation of this is done in the discussion of the shear analogy method presented in Section 3. Equation [5] is the final equation that explains how an apparent bending stiffness, EI_{app} , can be calculated by reducing the effective bending stiffness, EI_{eff} . In Equation [5], K_s is a constant based upon the influence of the shear deformation and is solved for various loading conditions in Table 2.

$$EI_{app} = \frac{EI_{eff}}{1 + \frac{K_s EI_{eff}}{GA_{eff} L^2}} \quad [5]$$

SHEAR →

Table 2
K_s values for various loading conditions

Loading	End Fixity	K _s
Uniformly distributed	Pinned	11.5
	Fixed	57.6
Concentrated at midspan	Pinned	14.4
	Fixed	57.6
Concentrated at quarter points	Pinned	10.5
Constant moment	Pinned	11.8
Uniformly distributed	Cantilevered	4.8
Concentrated at free-end	Cantilevered	3.6

Cross-Laminated Timber - Shear

2.1.2 Bending Members: Shear (Out-of-plane)

Similar to the flexural strength, a simplified method using the extreme fiber capacity is also available and has been proposed for the PRG 320 product standard. Using the simplified method, an effective $(Ib/Q)_{eff}$ can be calculated as follows:

$$\frac{(Ib/Q)_{eff}}{EI_{eff}} = \frac{1}{\sum_{i=1}^{n/2} E_i h_i z_i} \quad [3]$$

$F_v = \frac{VQ}{Ib}$
 $V = F_v \frac{Ib}{Q}$

where:

- EI_{eff} = Effective bending stiffness
- E_i = Modulus of elasticity of an individual layer
- h_i = Thickness of an individual layer, except the middle layer, which is half its thickness
- z_i = Distance from the centroid of the layer to the neutral axis, except for the middle layer, where it is to the centroid of the top half of that layer.

Manufacturers will likely have already done this calculation to give the shear capacity of the member. In equation form, design would appear as follows:

$$V_{planar} \leq F'_v (Ib/Q)_{eff} \quad [4]$$

C_D	C_M	C_t
-------	-------	-------

where:

- V_{planar} = induced shear due to loads
- $F'_v (Ib/Q)_{eff}$ = shear strength of the panel provided by the manufacture or calculated per the simplified method multiplied by the applicable adjustment factors.

2.2 Compression Members

2.2.1 Solid Columns and Walls

The column stability factor deserves additional discussion due to its complexity and reliance on other design values. For column and wall design, the load must be less than the adjusted compression strength multiplied by the area of the laminations where the grain is running parallel to the load, or in equation form as follows:

$$P_{parallel} \leq F'_c A_{parallel} \quad \boxed{C_D \quad C_M \quad C_t \quad - \quad C_p} \quad [6]$$

where:

- $P_{parallel}$ = Load applied parallel to the direction of the fibers
- F'_c = Adjusted compression strength
- $A_{parallel}$ = Area of layers with fibers running parallel to the direction of the load

Cross-Laminated Timber - Compression Adjustment Factors

2.2.2 Column Stability Factor, C_p

The column stability factor accounts for tendency of a column to buckle. Since CLT is a plate element, buckling only needs to be checked in the out-of-plane direction. Derived from the NDS, the formula for the column stability factor for CLT it is as follows:

$$C_p = \frac{1 + \overset{\text{Factor}}{(P_{cE} / P_c^*)}}{2c} - \sqrt{\left[\frac{1 + (P_{cE} / P_c^*)}{2c} \right]^2 - \frac{P_{cE} / P_c^*}{c}} \quad [7]$$

where:

P'_c = Composite compression design capacity ($F'_c \cdot A$) where F'_c is multiplied by all applicable adjustment factors except C_p

c = 0.9 for CLT

$$P_{cE} = \frac{\pi^2 EI'_{app-min}}{l_e^2} \quad (\text{see Section 2.2.3}).$$

C_M	C_t
-------	-------

2.2.3 Minimum Apparent Bending Stiffness, $EI_{app-min}$

The apparent bending stiffness, EI_{app} , should be determined using Equation [5]. The following equation can be used to adjust the average EI_{app} to a minimum value, $EI_{app-min}$, for use in column buckling design:

$$EI_{app-min} = 0.5184 EI_{app} \quad [8]$$

2.3 Tension Members

As wood should not be relied upon to resist tension perpendicular to the grain, only the grain parallel to the load should be included as the effective area. The total load has to be less than the adjusted tension strength multiplied by the area of the laminations where the grain is parallel to the load. In equation form,

$$T_{parallel} \leq F'_t A_{parallel} \quad \boxed{C_D \quad C_M \quad C_t} \quad [9]$$

where:

$T_{parallel}$ = Load applied parallel to the direction of the fibers

F'_t = Adjusted tensile strength

$A_{parallel}$ = Area of layers with fibers running parallel to the direction of the load.

Cross-Laminated Timber - Adjustment Factors

2.4 Bending and Axially Loaded Members

For members undergoing both axial compression and flat-wise bending, an equation from chapter 15 of the NDS has been modified from stress inputs to loads for CLT.

$$\underbrace{\left(\frac{P}{F'_c A_{parallel}}\right)^2}_C + \underbrace{\frac{M + P\Delta \left(1 + 0.234 \frac{P}{P_{cE}}\right)}{F'_b S_{eff} \left(1 - \frac{P}{P_{cE}}\right)}}_F \leq 1.0 \quad [10]$$

where:

P = Induced axial load

M = Induced bending moment

Δ = Eccentricity of axial load, measured perpendicular to the plane of the panel

P_{cE} = Critical buckling load (see Section 2.2.2).

2.5 Bearing of Members

2.5.1 Perpendicular to the Grain

The bearing area factor for CLT is 1.0, so is not included in Table 1. The design equation is as follows:

$$P \leq F'_{c\perp} A \quad \left[\begin{array}{|c|c|} \hline C_M & C_t \\ \hline \end{array} \right] \quad [11]$$

where:

P = Load applied

$F'_{c\perp}$ = Adjusted compression perpendicular to grain design value.

2.5.2 Parallel to the Grain

For bearing parallel to the grain or with a combination of parallel and perpendicular to grain, such as the bottom of a wall, parallel to the grain will dominate over perpendicular. The design equation is the following:

$$P_{parallel} \leq F_c^* A_{parallel} \quad [12]$$

where:

$P_{parallel}$ = Load applied parallel to the direction of the fibers

F_c^* = Reference compression parallel to grain design value multiplied by all applicable adjustment factors except the column stability factor, C_p

$A_{parallel}$ = Area of layers with fibers running parallel to the direction of the load.

Cross-Laminated Timber - Flexure Example

Given: Span = 30 ft.
 CLT PRG 320 E1
 5 layer, h = 6.875 in

Find: Load capacity ?

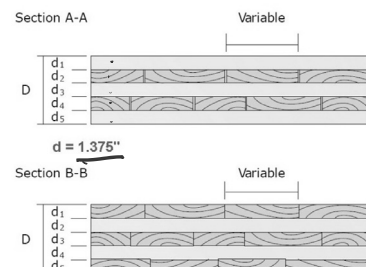
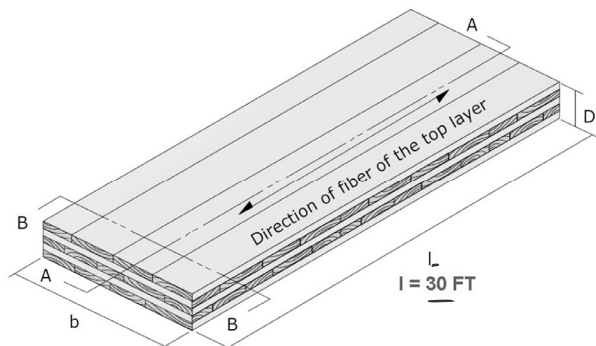

Cross-Laminated Timber - Flexure Example

TABLE A1.
ALLOWABLE DESIGN PROPERTIES^(a,b,c) FOR PRG 320 CLT (for use in the U.S.)

CLT Grades	Major Strength Direction						Minor Strength Direction					
	F _{b,0} (psi)	E ₀ (10 ⁶ psi)	F _{t,0} (psi)	F _{c,0} (psi)	F _{v,0} (psi)	F _{s,0} (psi)	F _{b,90} (psi)	E ₉₀ (10 ⁶ psi)	F _{t,90} (psi)	F _{c,90} (psi)	F _{v,90} (psi)	F _{s,90} (psi)
E1	1,950	1.7	1,375	1,800	135	45	500	1.2	250	650	135	45
E2	1,650	1.5	1,020	1,700	180	60	525	1.4	325	775	180	60
E3	1,200	1.2	600	1,400	110	35	350	0.9	150	475	110	35
E4	1,950	1.7	1,375	1,800	175	55	575	1.4	325	825	175	55
V1	900	1.6	575	1,350	180	60	525	1.4	325	775	180	60
V2	875	1.4	450	1,150	135	45	500	1.2	250	650	135	45
V3	975	1.6	550	1,450	175	55	575	1.4	325	825	175	55

For SI: 1 psi = 0.006895 MPa

(a) See Section 4 for symbols.

(b) Tabulated values are allowable design values and not permitted to be increased for the lumber size adjustment factor in accordance with the NDS. The design values shall be used in conjunction with the section properties provided by the CLT manufacturer based on the actual layout used in manufacturing the CLT panel (see Table A2).

(c) Custom CLT grades that are not listed in this table shall be permitted in accordance with Section 7.2.1

Cross-Laminated Timber - Flexure Example

To find $S = I/c = 2 I/h$, first find I (or $E I_{eff}$)

Calculation of section stiffness – $E I_{eff}$

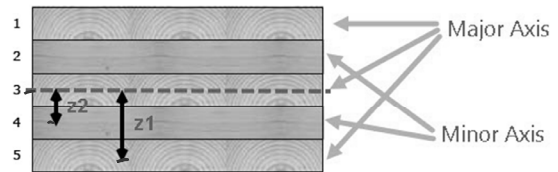

Figure 6
Cross-section of a 5-layer CLT panel

For a 5-layer, E1 panel:

h_1 = Thickness of an individual layer = 1 3/8 in. values for all layers
 b = Design width = 12 in.

Major strength axis (parallel to grain) values from Table 1
 F_{b0} = Bending strength = 1950 psi
 E_0 = Modulus of elasticity = 1.7×10^6 psi PRG-320

Minor strength axis (perpendicular to grain)
 F_{b90} = Bending strength = 500 psi
 E_0 = Modulus of elasticity = 1.2×10^6 psi

$$EI_{eff} = \sum_{i=1}^n E_i \cdot b_i \cdot \frac{h_i^3}{12} + \sum_{i=1}^n E_i \cdot A_i \cdot z_i^2 \quad [24]$$

Table 3
Parallel axis theorem calculations for $E I_{eff}$

Layer	E (x 10 ⁶ psi)	z (in.)	Ebh ³ /12 (lb.-in. ²)	EAz ² (lb.-in. ²)	Sum of Layer
1	1.7	2.75	4.4	212.1	216.5
2	1.2/30=0.04	1.375	0.1	1.2	1.4
3	1.7	0.0	4.4	0.0	4.4
4	0.04	1.375	0.1	1.2	1.4
5	1.7	2.75	4.4	212.1	216.5
				Total	440

$E I_{eff}$

Cross-Laminated Timber - Flexure Example

Calculation of section modulus:
 S_{eff}

$$S_{eff} = \frac{2EI_{eff}}{E_1 h} = \frac{2 \times 440}{1.7 \times 6.875} = 75.29 \text{ in.}^3$$

Calculation of bending moment:
 $M = F'_b S_{eff}$

$$M = \frac{F_b S_{eff}}{12} = \frac{0.85 \times 1950 \times 75.29}{12} = 10,400 \text{ lb.-ft.}$$

moment capacity

For a uniform beam loading per foot:

$$M = \frac{w l^2}{8} = 10400 \text{ ft-lbs}$$

$$w = \frac{10400 \times 8}{30^2} = 92 \text{ psf}$$

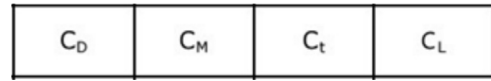

Cross-Laminated Timber - Allowable Bending Capacity

CLT PRG 320 E1
 5 layer, h = 6.875 in.

TABLE A2.
 THE ALLOWABLE BENDING CAPACITIES^(a,b,c) FOR CLT LISTED IN TABLE A1 (FOR USE IN THE U.S.)

CLT Grade	Lamination Thickness (in.) in CLT Layout					Major Strength Direction			Minor Strength Direction		
	CLT 1 (in.)	=	⊥	=	⊥	M F _b S _{eff,0} (lb-ft/ft)	EI _{eff,0} (10 ⁶ lb-ft-in. ² /ft)	GA _{eff,0} (10 ⁶ lb/ft)	F _b S _{eff,90} (lb-ft/ft)	EI _{eff,90} (10 ⁶ lb-ft-in. ² /ft)	GA _{eff,90} (10 ⁶ lb/ft)
E1	4 1/8	1 3/8	1 3/8	1 3/8	4 1/8	4,525	115	0.46	160	3.1	0.61
	6 7/8	1 3/8	1 3/8	1 3/8	1 3/8	10,400	440	0.92	1,370	81	1.2
	9 5/8	1 3/8	1 3/8	1 3/8	1 3/8	18,375	1,089	1.4	3,125	309	1.8
E2	4 1/8	1 3/8	1 3/8	1 3/8	4 1/8	3,825	102	0.53	165	3.6	0.56
	6 7/8	1 3/8	1 3/8	1 3/8	1 3/8	8,825	389	1.1	1,430	95	1.1
	9 5/8	1 3/8	1 3/8	1 3/8	1 3/8	15,600	963	1.6	3,275	360	1.7
E3	4 1/8	1 3/8	1 3/8	1 3/8	4 1/8	2,800	81	0.35	110	2.3	0.44
	6 7/8	1 3/8	1 3/8	1 3/8	1 3/8	6,400	311	0.69	955	61	0.87
	9 5/8	1 3/8	1 3/8	1 3/8	1 3/8	11,325	769	1.0	2,180	232	1.3
E4	4 1/8	1 3/8	1 3/8	1 3/8	4 1/8	4,525	115	0.53	180	3.6	0.63
	6 7/8	1 3/8	1 3/8	1 3/8	1 3/8	10,425	441	1.1	1,570	95	1.3
	9 5/8	1 3/8	1 3/8	1 3/8	1 3/8	18,400	1,090	1.6	3,575	360	1.9
V1	4 1/8	1 3/8	1 3/8	1 3/8	4 1/8	2,090	108	0.53	165	3.6	0.59
	6 7/8	1 3/8	1 3/8	1 3/8	1 3/8	4,800	415	1.1	1,430	95	1.2
	9 5/8	1 3/8	1 3/8	1 3/8	1 3/8	8,500	1,027	1.6	3,275	360	1.8
V2	4 1/8	1 3/8	1 3/8	1 3/8	4 1/8	2,030	95	0.46	160	3.1	0.52
	6 7/8	1 3/8	1 3/8	1 3/8	1 3/8	4,675	363	0.91	1,370	81	1.0
	9 5/8	1 3/8	1 3/8	1 3/8	1 3/8	8,275	898	1.4	3,125	309	1.6
V3	4 1/8	1 3/8	1 3/8	1 3/8	4 1/8	2,270	108	0.53	180	3.6	0.59
	6 7/8	1 3/8	1 3/8	1 3/8	1 3/8	5,200	415	1.1	1,570	95	1.2
	9 5/8	1 3/8	1 3/8	1 3/8	1 3/8	9,200	1,027	1.6	3,575	360	1.8

For SI: 1 in. = 25.4 mm; 1 ft = 304.8 mm; 1 lbf = 4.448 N

(a) See Section 4 for symbols.

(b) This table represents one of many possibilities that the CLT could be manufactured by varying lamination grades, thicknesses, orientations, and layer arrangements in the layout.

(c) Custom CLT grades that are not listed in this table shall be permitted in accordance with Section 7.2.1.

APA PRG 320

Cross-Laminated Timber connections

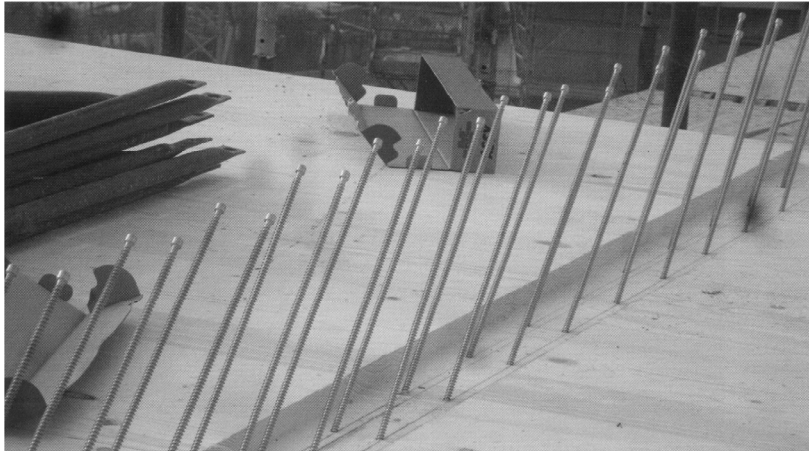

Cross-Laminated Timber Wall to Foundation Details

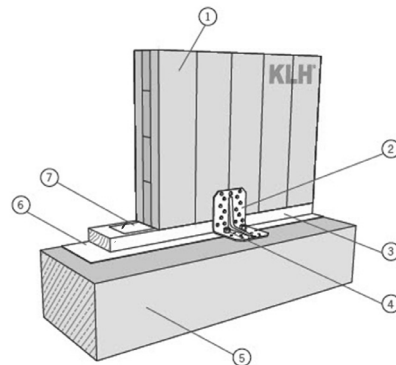
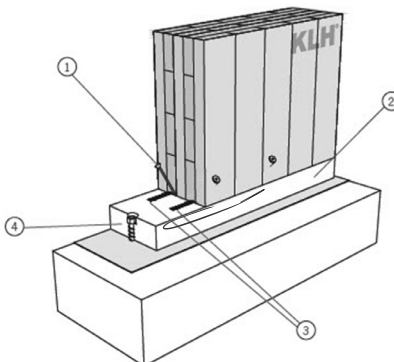
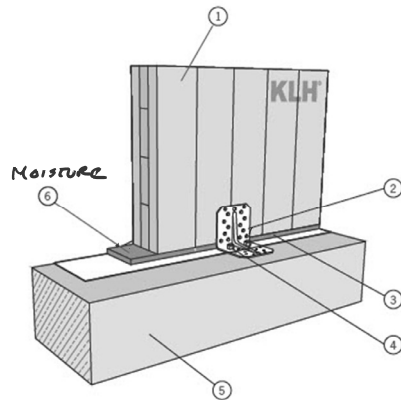
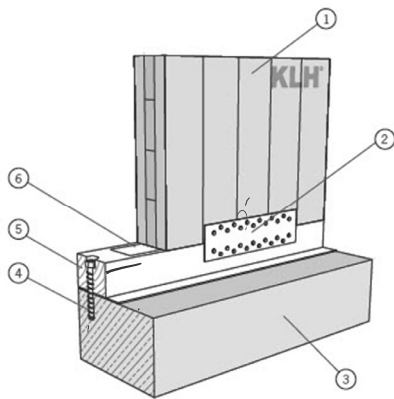

Cross-Laminated Timber Wall to Wall Details

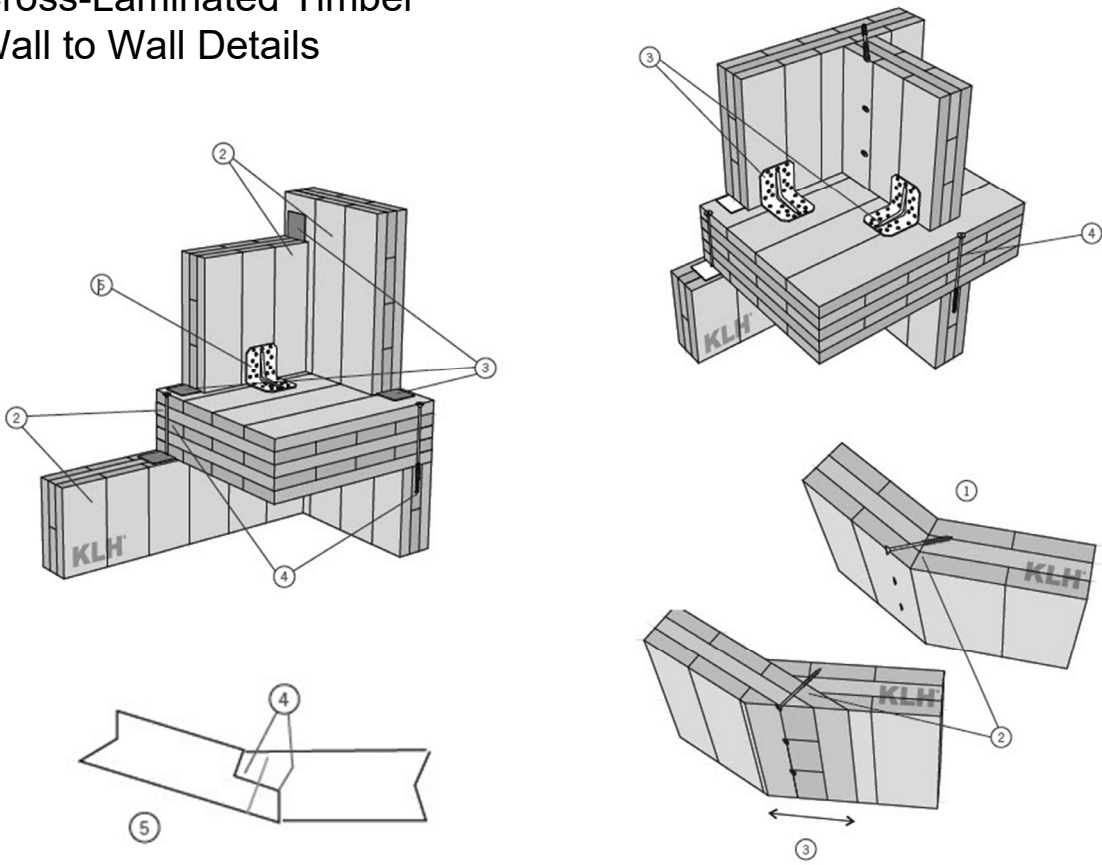

Cross-Laminated Timber Wall to Roof Details

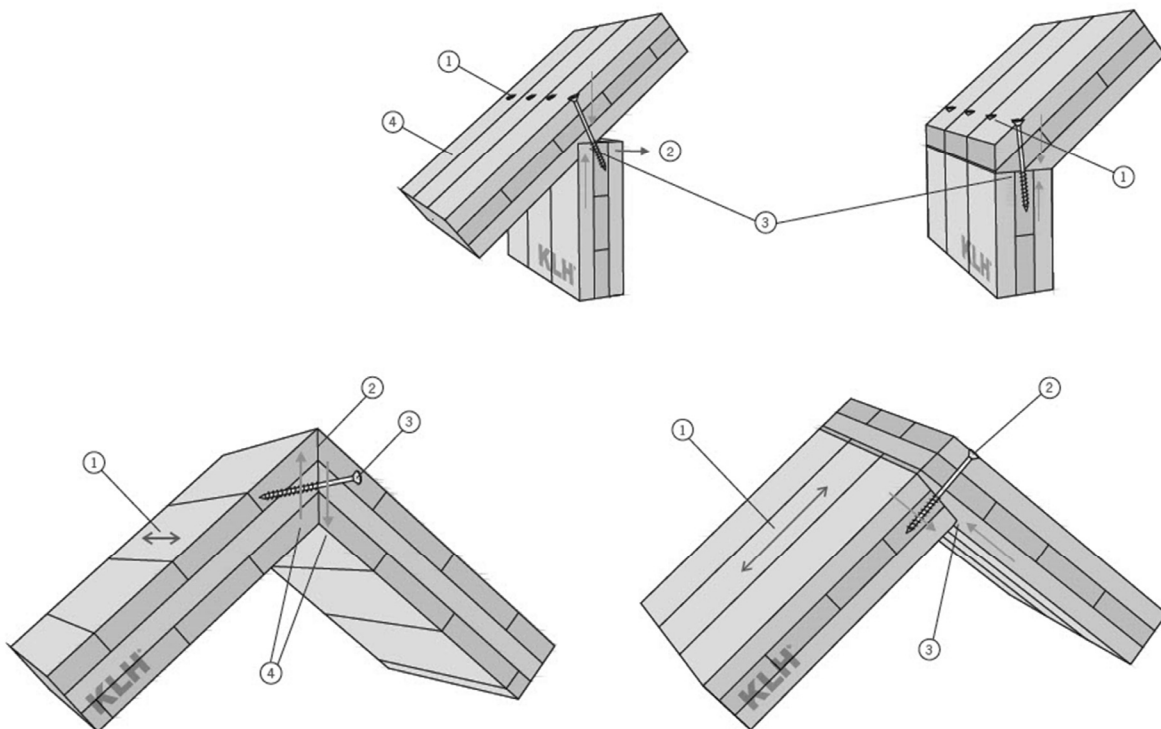

Cross-Laminated Timber Floor Details

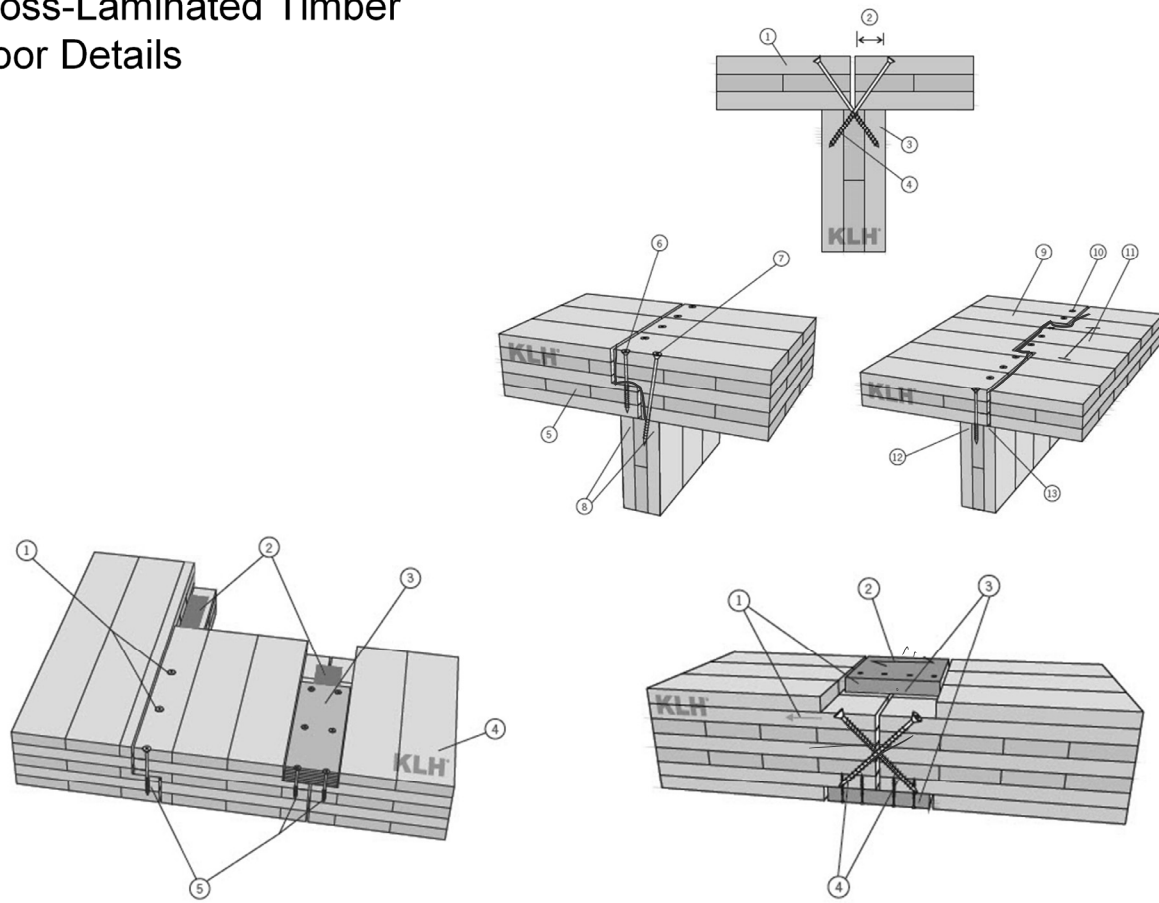

Cross-Laminated Timber Construction Sequence - Slab to Roof in 2 Weeks



Bodenplatte in Panoramaansicht



Die ersten Seitenteile stehen



Alle Wände im EG stehen

R&S Münsterländer Holz & Elementbau GmbH, Lüdinghausen, Germany



Beginn des Ausbaus 1. EG



Innenansicht



Dachstuhl





THÉÂTRE VIDY LAUSANNE: A DOUBLE-LAYERED TIMBER FOLDED PLATE STRUCTURE

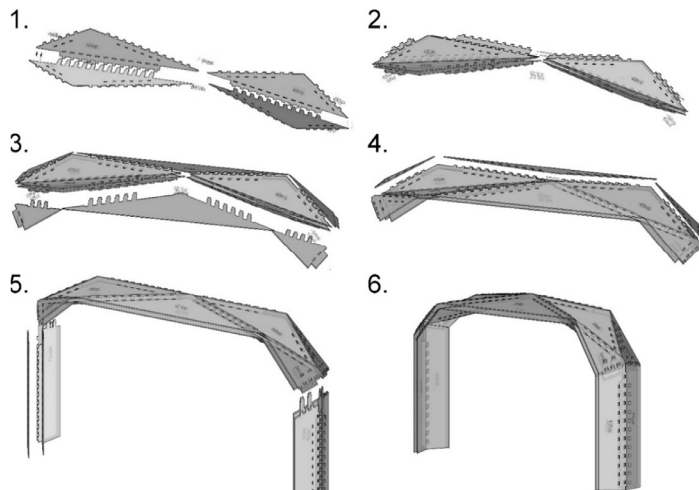
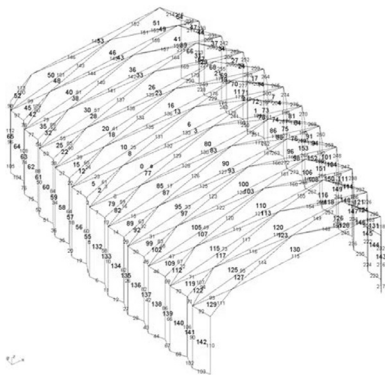

Six step fabrication and erection. Steps 1-4 prefabricated. Step 5 assembly at site..

Double layer folded plate assembly with through tenons.

THÉÂTRE VIDY LAUSANNE

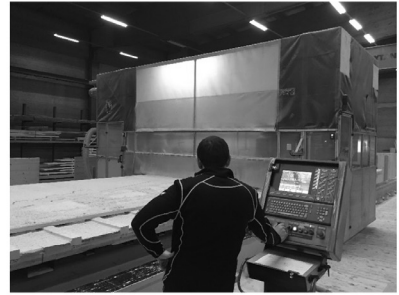
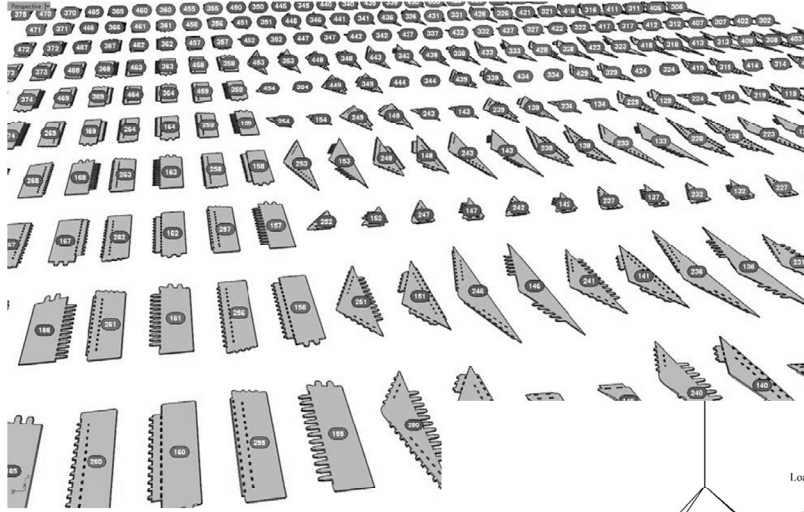

Details of CNC 5-axis routing of tenons

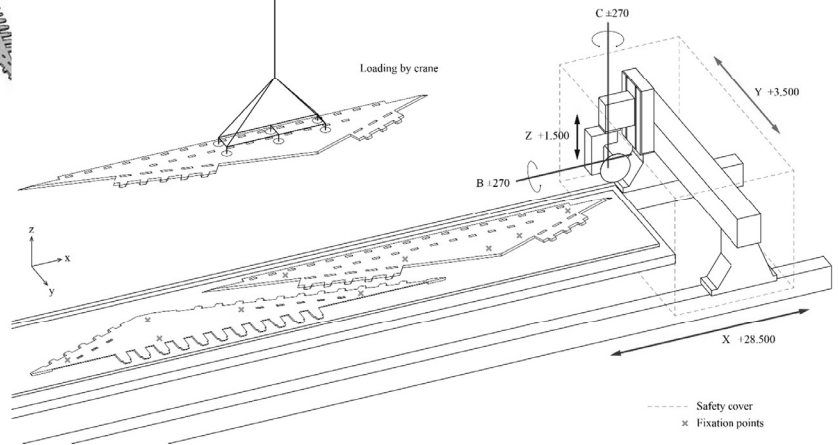

THÉÂTRE VIDY LAUSANNE



Shell assembly at fabrication shop





University of Michigan, TCAUP

Structures II

Slide 37/29

Cross-Laminated Timber Examples



Kindergarten Josef-Felderstr. 29, Augsburg
Architektur: Hiendl & Partner Architekten, Passau

University of Michigan, TCAUP

Structures II

Slide 38 of 42

Cross-Laminated Timber Examples

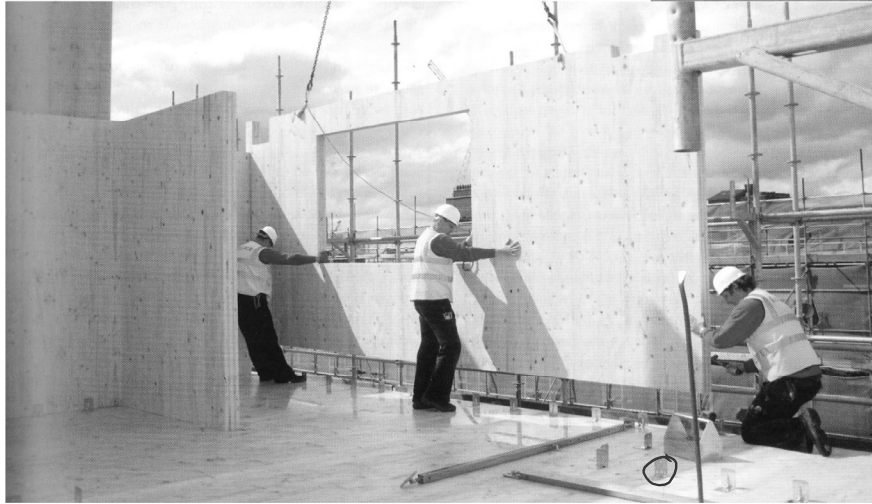

**“Honeycomb” construction
in UK**

University of Michigan, TCAUP

Structures II

Slide 39 of 42

Cross-Laminated Timber

**Worcester Library and History Center
“The Hive”**

**Architect: Feilden Clegg Bradley
Studios**

Engineer: Hyder Consulting

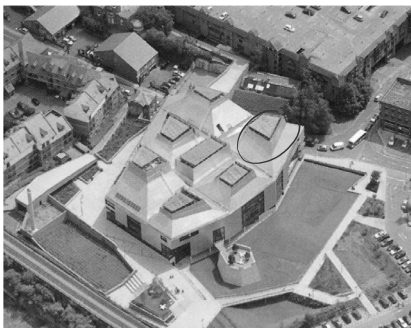

University of Michigan, TCAUP

Structures II

Slide 40 of 42

Cross-Laminated Timber “The Hive”

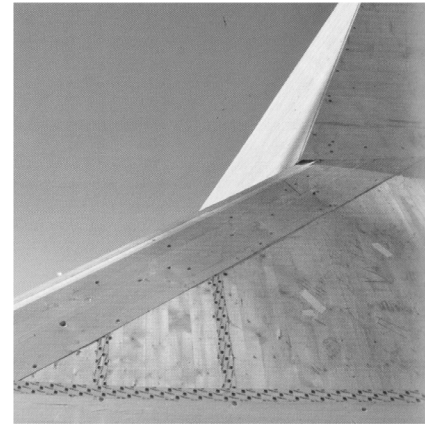

More CLT resources and examples <https://www.thinkwood.com/>

THINK WOOD

NEWS BLOG ABOUT CONTACT **▲ SUSTAINABLE BUILDING RESOURCES**

Why Wood? Design + Build Timber Products Sustainability Wood At Home Project Gallery Education 🔍

THINK WOOD

The whole wood world.

Reimagine the possibilities of wood in the built environment. We'll show you how wood can elevate your projects (literally), meet budgets, achieve sustainability goals, and create awe-inspiring structures.