

Reinforced Concrete Beams Ultimate Strength Design (ACI 318-14) – PART II

- Reinforcement Detailing
- Reinforced Concrete Examples
- 3D-Print Evolution (Video)

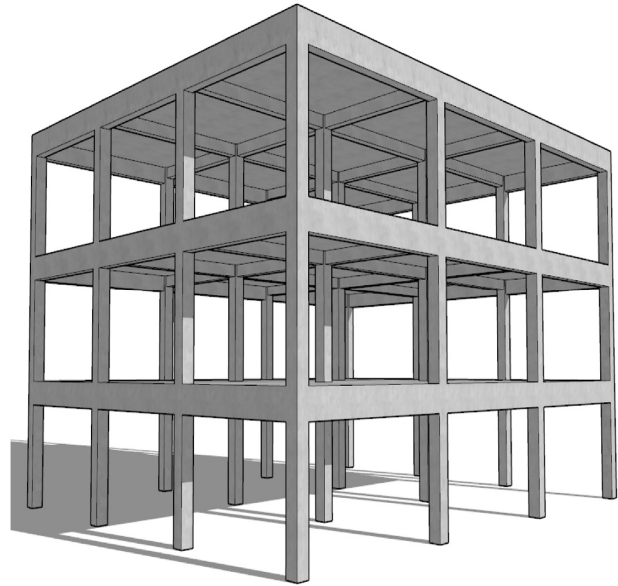

Details of Reinforcement

Size

- Nominal 1/8" increments

Grade

- 40 (40 ksi) ← OLDER
- 60 (60 ksi) ← STANDARD
- 75 (75 ksi) ← HIGHER

Bar size designation	Nominal cross section area, sq. in.	Weight, lb per ft	Nominal diameter, in.
#3	0.11	0.376	0.375
#4	0.20	0.668	0.500
#5	0.31	1.043	0.625
#6	0.44	1.502	0.750
#7	0.60	2.044	0.875
#8	0.79	2.670	1.000
#9	1.00	3.400	1.128
#10	1.27	4.303	1.270
#11	1.56	5.313	1.410
#14	2.25	7.650	1.693
#18	4.00	13.600	2.257

3/8
4/8
5/8
6/8

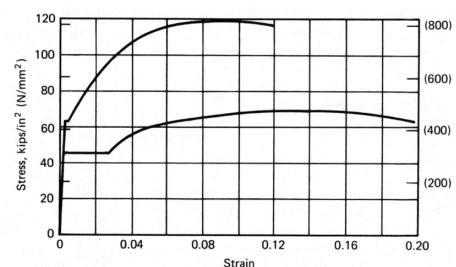

Details of Reinforcement

ACI 318 Chapter 25.2 Placement of Reinforcement

- Cover (ACI 20.6.1)
- Horizontal spacing in beams, s_h (ACI 25.2.1)

$$\frac{1 \text{ inch}}{\frac{d_b}{4/3 d_{agg,max}}} \text{ MIN}$$

- Vertical spacing in beams (ACI 25.2.2)
Min 1 inch



<https://www.constructioncost.co/honeycombing-in-concrete.html>

Table 20.6.1.3.1—Specified concrete cover for cast-in-place nonprestressed concrete members

Concrete exposure	Member	Reinforcement	Specified cover, in.
Cast against and permanently in contact with ground	All	All	3
Exposed to weather or in contact with ground ?	All	No. 6 through No. 18 bars	2
		No. 5 bar, W31 or D31 wire, and smaller	1-1/2
Not exposed to weather or in contact with ground	Slabs, joists, and walls	No. 14 and No. 18 bars	1-1/2
		No. 11 bar and smaller	3/4
	Beams, columns, pedestals, and tension ties	Primary reinforcement, stirrups, ties, spirals, and hoops	1-1/2

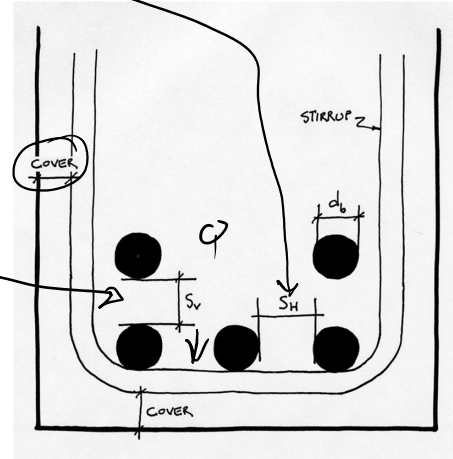

Details of Reinforcement

ACI 318 Chapter 25 Placement of Reinforcement

- Chairs
- Bolsters



<https://catalog.formtechinc.com>



<http://contractorsupplymagazine.com>

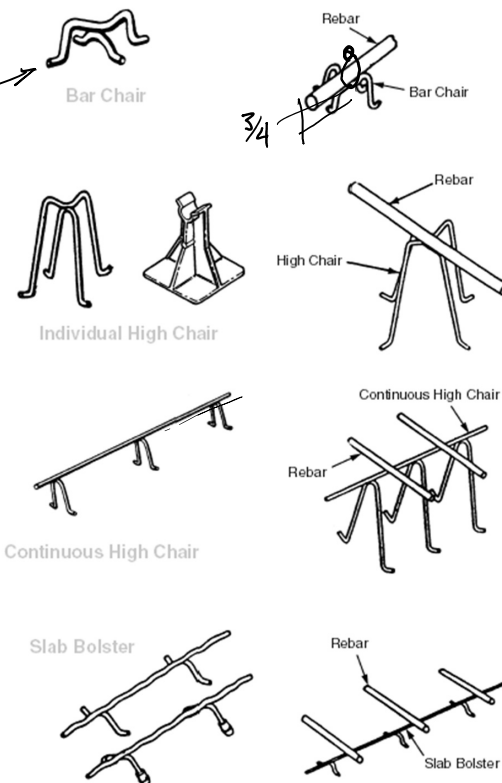

Details of Reinforcement

ACI 318 Chapter 25

Minimum bend diameter

- factor x d_b

Hooks for bars in tension

- ACI Table 25.3.1
- Inside diameter

Bends for stirrups

- ACI Table 25.3.2

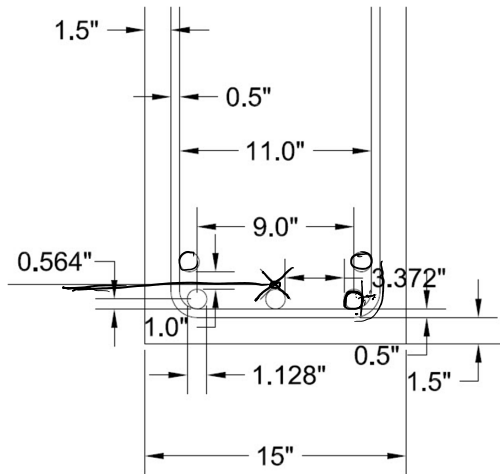

University of Michigan, TCAUP

Table 25.3.1—Standard hook geometry for development of deformed bars in tension

Type of standard hook	Bar size	Minimum inside bend diameter, in.	Straight extension ¹⁾ ℓ_{ext} , in.	Type of standard hook
90-degree hook	No. 3 through No. 8	$6d_b$	$12d_b$	
	No. 9 through No. 11	$8d_b$		
	No. 14 and No. 18	$10d_b$		
180-degree hook	No. 3 through No. 8	$6d_b$	Greater of $4d_b$ and 2.5 in.	
	No. 9 through No. 11	$8d_b$		
	No. 14 and No. 18	$10d_b$		

¹⁾A standard hook for deformed bars in tension includes the specific inside bend diameter and straight extension length. It shall be permitted to use a longer straight extension at the end of a hook. A longer extension shall not be considered to increase the anchorage capacity of the hook.

Table 25.3.2—Minimum inside bend diameters and standard hook geometry for stirrups, ties, and hoops

Type of standard hook	Bar size	Minimum inside bend diameter, in.	Straight extension ¹⁾ ℓ_{ext} , in.	Type of standard hook
90-degree hook	No. 3 through No. 5	$4d_b$	Greater of $6d_b$ and 3 in.	
	No. 6 through No. 8	$6d_b$	$12d_b$	
135-degree hook	No. 3 through No. 5	$4d_b$	Greater of $6d_b$ and 3 in.	
	No. 6 through No. 8	$6d_b$		
180-degree hook	No. 3 through No. 5	$4d_b$	Greater of $4d_b$ and 2.5 in.	
	No. 6 through No. 8	$6d_b$		

¹⁾A standard hook for stirrups, ties, and hoops includes the specific inside bend diameter and straight extension length. It shall be permitted to use a longer straight extension at the end of a hook. A longer extension shall not be considered to increase the anchorage capacity of the hook.

Structures II

Slide 5 of 21

Details of Reinforcement

ACI 318 Chapter 25

Development length of bars

- 12" min
- Based on table 25.4.2.2

Table 25.4.2.4—Modification factors for development of deformed bars and deformed wires in tension

Modification factor	Condition	Value of factor
Lightweight λ	Lightweight concrete	0.75
	Lightweight concrete, where f_{cr} is specified	In accordance with 19.2.4.3
	Normalweight concrete	1.0
Epoxy ¹⁾ ψ_e	Epoxy-coated or zinc and epoxy dual-coated reinforcement with clear cover less than $3d_b$ or clear spacing less than $6d_b$	1.5
	Epoxy-coated or zinc and epoxy dual-coated reinforcement for all other conditions	1.2
	Uncoated or zinc-coated (galvanized) reinforcement	1.0
Size ψ_s	No. 7 and larger bars	1.0
	No. 6 and smaller bars and deformed wires	0.8
Casting position ¹⁾ ψ_t	More than 12 in. of fresh concrete placed below horizontal reinforcement	1.3
	Other	1.0

¹⁾The product $\psi_s \psi_e$ need not exceed 1.7.

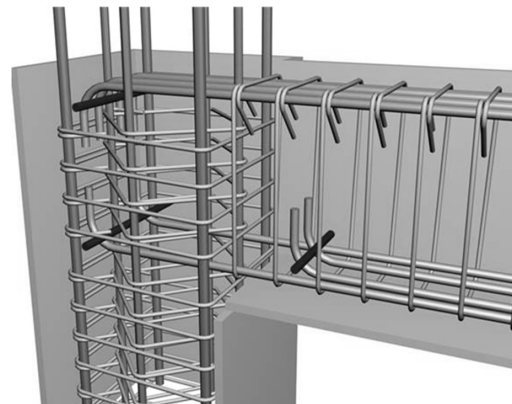

<https://www.buildinghow.com>

Table 25.4.2.2—Development length for deformed bars and deformed wires in tension

Spacing and cover	No. 6 and smaller bars and deformed wires	No. 7 and larger bars
Clear spacing of bars or wires being developed or lap spliced not less than d_b , clear cover at least d_b , and stirrups or ties throughout ℓ_d not less than the Code minimum or Clear spacing of bars or wires being developed or lap spliced at least $2d_b$ and clear cover at least d_b	$\left(\frac{f_y \psi_t \psi_e}{25 \lambda \sqrt{f'_c}} \right) d_b$	$\left(\frac{f_y \psi_t \psi_e}{20 \lambda \sqrt{f'_c}} \right) d_b$
Other cases	$\left(\frac{3 f_y \psi_t \psi_e}{50 \lambda \sqrt{f'_c}} \right) d_b$	$\left(\frac{3 f_y \psi_t \psi_e}{40 \lambda \sqrt{f'_c}} \right) d_b$

University of Michigan, TCAUP

Structures II

Slide 6 of 21

Other Useful Tables:

Table A.1 Values of Modulus of Elasticity for Normal-Weight Concrete

Customary Units		SI Units	
f'_c (psi)	E_c (psi)	f'_c (MPa)	E_c (MPa)
3,000	3,140,000	20.7	21 650
3,500	3,390,000	24.1	23 373
4,000	3,620,000	27.6	24 959
4,500	3,850,000	31.0	26 545
5,000	4,050,000	34.5	27 924

Jack C McCormac, 1978, *Design of Reinforced Concrete*.

Table A.2 Designations, Areas, Perimeters, and Weights of Standard Bars

Bar No.	Customary Units			SI Units		
	Diameter (in.)	Cross-sectional Area (in. ²)	Unit Weight (lb/ft)	Diameter (mm)	Cross-sectional Area (mm ²)	Unit Weight (kg/m)
3	0.375	0.11	0.376	9.52	71	0.560
4	0.500	0.20	0.668	12.70	129	0.994
5	0.625	0.31	1.043	15.88	200	1.552
6	0.750	0.44	1.502	19.05	284	2.235
7	0.875	0.60	2.044	22.22	387	3.042
8	1.000	0.79	2.670	25.40	510	3.973
9	1.128	1.00	3.400	28.65	645	5.060
10	1.270	1.27	4.303	32.26	819	6.404
11	1.410	1.56	5.313	35.81	1006	7.907
14	1.693	2.25	7.650	43.00	1452	11.384
18	2.257	4.00	13.600	57.33	2581	20.238

Table A.4 Areas of Groups of Standard Bars (in.²)

Bar No.	Number of Bars												
	2	3	4	5	6	7	8	9	10	11	12	13	14
4	0.39	0.58	0.78	0.98	1.18	1.37	1.57	1.77	1.96	2.16	2.36	2.55	2.75
5	0.61	0.91	1.23	1.53	1.84	2.15	2.45	2.76	3.07	3.37	3.68	3.99	4.30
6	0.88	1.32	1.77	2.21	2.65	3.09	3.53	3.98	4.42	4.86	5.30	5.74	6.19
7	1.20	1.80	2.41	3.01	3.61	4.21	4.81	5.41	6.01	6.61	7.22	7.82	8.42
8	1.57	2.35	3.14	3.93	4.71	5.50	6.28	7.07	7.85	8.64	9.43	10.21	11.00
9	2.00	3.00	4.00	5.00	6.00	7.00	8.00	9.00	10.00	11.00	12.00	13.00	14.00
10	2.53	3.79	5.06	6.33	7.59	8.86	10.12	11.39	12.66	13.92	15.19	16.45	17.72
11	3.12	4.68	6.25	7.81	9.37	10.94	12.50	14.06	15.62	17.19	18.75	20.31	21.87
14	4.50	6.75	9.00	11.25	13.50	15.75	18.00	20.25	22.50	24.75	27.00	29.25	31.50
18	8.00	12.00	16.00	20.00	24.00	28.00	32.00	36.00	40.00	44.00	48.00	52.00	56.00

Ferrocement

- Pioneered by Pier Luigi Nervi
- Dense, small gage reinforcement
- More flexible shapes – no formwork
- Well suited for thin shells
- Less cracking

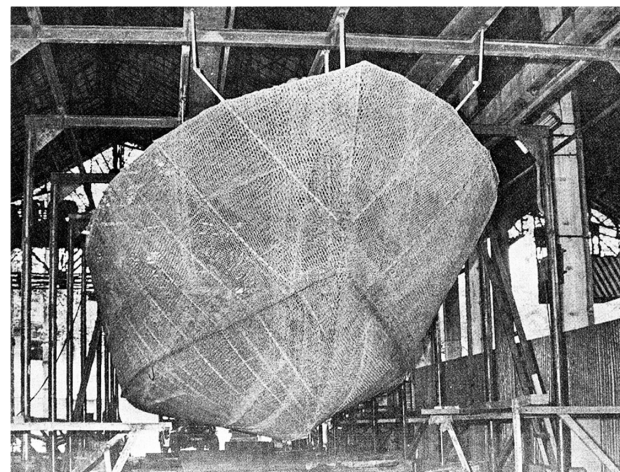
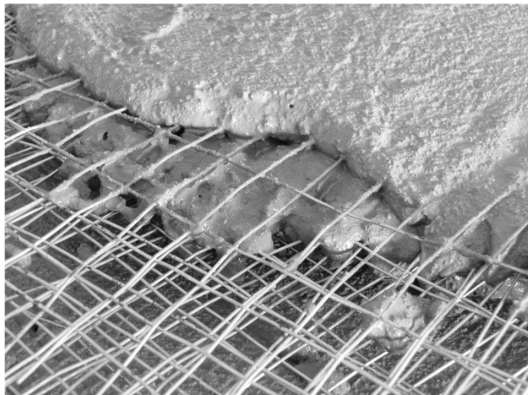
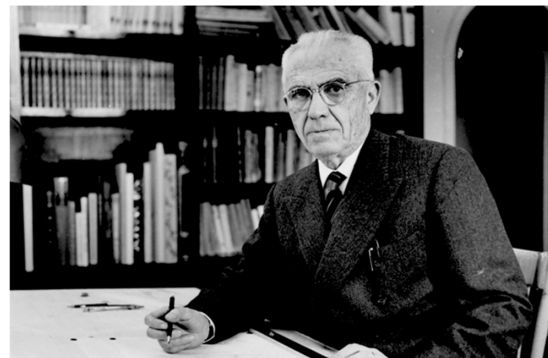

Ferrocement

- Pioneered by Nervi
- Dense, small gage reinforcement
- More flexible shapes – no formwork
- Well suited for thin shells
- Less cracking
- Low-tech applications



Priory Benedictine Church, Missouri, 1956. Architect Gyo Obata



Palazetto dello Sport, Rome, 1957. P.L. Nervi

Fiber Reinforced Concrete

Several different fiber types:

- Steel (SFRC)
- Glass (GFRC)
- Plastic e.g. polypropylene
- Carbon
- Organic e.g. bamboo

Better crack control

Secondary reinforcement

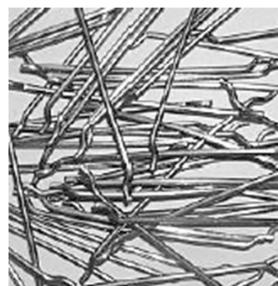
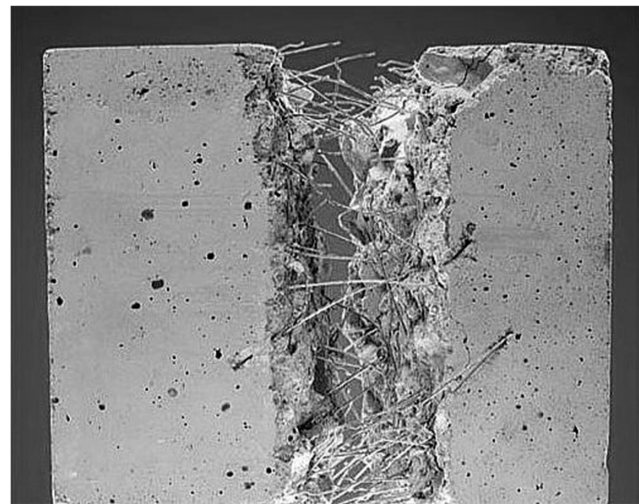

Single



Wave



Bundle

Glass Fiber Reinforced Concrete - GFRC

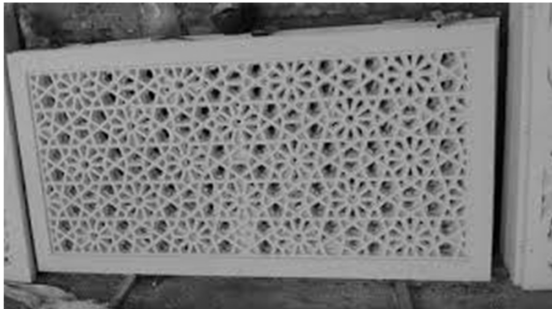

Carbon Fiber

Bamboo



Textile Reinforced Concrete (TRC)

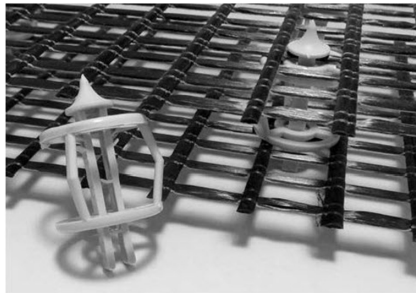
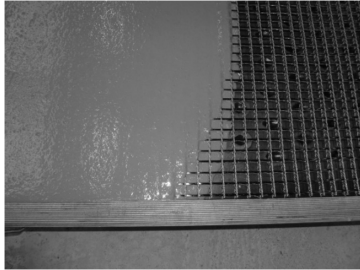
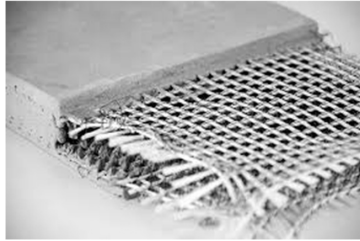

Figure 12: distTEX: special spacers for textile grids [photo: Frank Schladitz, TU Dresden]



Figure 13: Manufacturing of the TRC hyper-shell layer by layer by shotcrete [photo: © RWTH Aachen], [38]



Figure 10: Demolding of a hardened shell element in the concrete yard in Kahla/Saxony [photo: Daniel Ehlig, TU Dresden]

Shotcrete

- Pneumatically applied
- High velocity
- Can include fiber
- Applied to backing
- Reinforced with bars
- Soil stabilization, tunnels

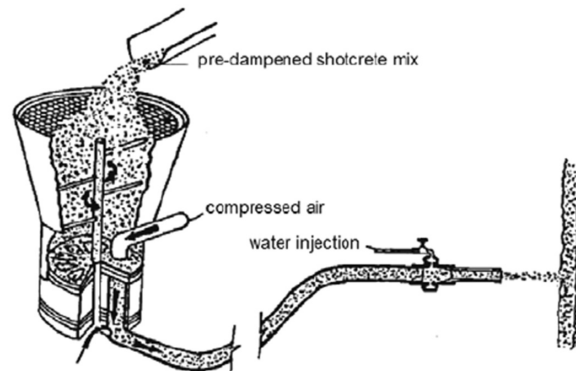

3D-Print Evolution

TED^x Zurich

x = independently organized TED event

THANK YOU

Platinum Partner



Gold Partner



MIGROS
kulturprozent



Silver Partner



Private
Banking

THEPOWEROFTEN

<https://www.youtube.com/watch?v=awpmJriWcEw>