

Architecture 324 Structures II

Wood Beam Analysis

- ASD approach
- NDS criteria
- Wood Beam Analysis

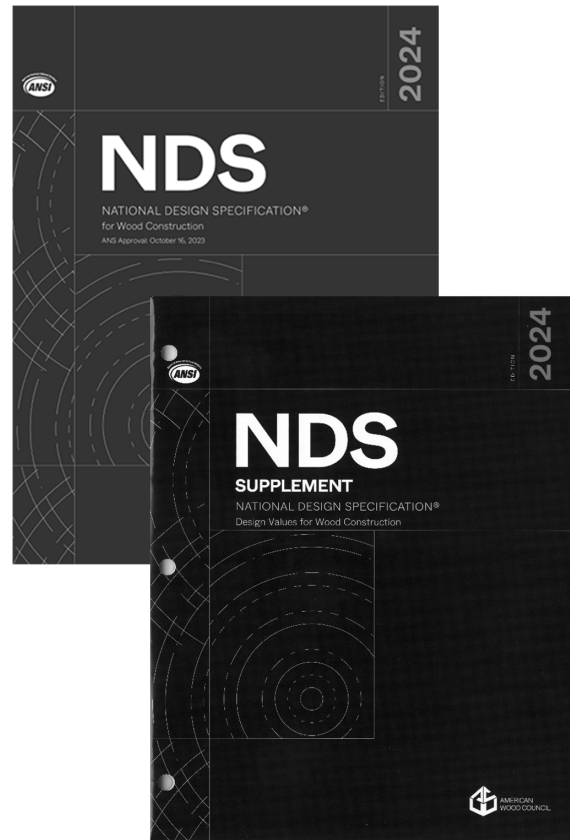

Allowable Stress Design by NDS Flexure

$$F_b' \geq f_b$$

Allowable Flexure Stress F_b'

F_b from NDS Supplement tables determined by species and grade

$$F_b' = F_b \text{ (usage factors)}$$

usage factors for flexure:

- C_D Load Duration Factor
- C_M Moisture Factor
- C_t Temperature Factor
- C_L Beam Stability Factor
- C_F Size Factor
- C_{fu} Flat Use
- C_i Incising Factor
- C_r Repetitive Member Factor

Actual Flexure Stress f_b

$$f_b = Mc/I = M/S$$

$$S = I/c = bd^2/6$$

Allowable Stress Design by NDS

Shear

$$F_v' \geq f_v$$

Allowable Shear Stress F_v'

F_v from tables determined by species and grade

$$F_v' = F_v \text{ (usage factors)}$$

usage factors for shear:

- C_D Load Duration Factor
- C_M Moisture Factor
- C_t Temperature Factor
- C_i Incising Factor

NDS Table 4.3.1

Actual Shear Stress f_v

$$f_v = VQ / I b = 1.5 V/A$$

Can use V at d from support as maximum

Shear at Supports

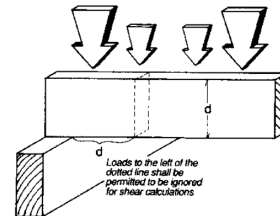

Allowable Stresses

From the NDS Supplement

DESIGN VALUES FOR WOOD CONSTRUCTION – NDS SUPPLEMENT

35

Table 4A (Cont.) Reference Design Values for Visually Graded Dimension Lumber (2" - 4" thick)^{1,2,3}

(All species except Southern Pine— see Table 4B) (Tabulated design values are for normal load duration and dry service conditions. See NDS 4.3 for a comprehensive description of design value adjustment factors.)

USE WITH TABLE 4A ADJUSTMENT FACTORS

Species and commercial grade	Size classification	Design values in pounds per square inch (psi)						Modulus of Elasticity		Specific Gravity ⁴	Grading Rules Agency
		Bending	Tension parallel to grain	Shear parallel to grain	Compression perpendicular to grain	Compression parallel to grain	E				
		F _b	F _t	F _v	F _{c⊥}	F _c		G			
HEM-FIR											
Select Structural		1,400	925	150	405	1,500	1,600,000	580,000			
No. 1 & Btr		1,100	725	150	405	1,350	1,500,000	550,000			
No. 1	2" & wider	975	625	150	405	1,350	1,500,000	550,000			
No. 2		850	525	150	405	1,300	1,300,000	470,000			
No. 3		500	300	150	405	725	1,200,000	440,000	0.43	WCLIB WWPA	
Stud	2" & wider	675	400	150	405	800	1,200,000	440,000			
Construction		975	600	150	405	1,550	1,300,000	470,000			
Standard	2" - 4" wide	550	325	150	405	1,300	1,200,000	440,000			
Utility		250	150	150	405	850	1,100,000	400,000			

Adjustment Factors

Table 4.3.1 – Applicability of Adjustment Factors for Sawn Lumber

	ASD only	ASD and LRFD											LRFD only		
		Load Duration Factor	Wet Service Factor	Temperature Factor	Beam Stability Factor	Size Factor	Flat Use Factor	Incising Factor	Repetitive Member Factor	Column Stability Factor	Buckling Stiffness Factor	Bearing Area Factor	Format Conversion Factor	Resistance Factor	Time-Effect Factor
												K_F	ϕ		
$F_b' = F_b$	x	C_D	C_M	C_t	C_L	C_F	C_{fu}	C_i	C_r	-	-	-	2.54	0.85	λ
$F_t' = F_t$	x	C_D	C_M	C_t	-	C_F	-	C_i	-	-	-	-	2.70	0.80	λ
$F_v' = F_v$	x	C_D	C_M	C_t	-	-	-	C_i	-	-	-	-	2.88	0.75	λ
$F_c' = F_c$	x	C_D	C_M	C_t	-	C_F	-	C_i	-	C_p	-	-	2.40	0.90	λ
$F_{c,L}' = F_{c,L}$	x	-	C_M	C_t	-	-	-	C_i	-	-	C_b	-	1.67	0.90	-
$E' = E$	x	-	C_M	C_t	-	-	C_{fu}^1	C_i	-	-	-	-	-	-	-
$E_{min}' = E_{min}$	x	-	C_M	C_t	-	-	C_{fu}^1	C_i	-	-	C_T	-	1.76	0.85	-

¹ Where sawn lumber of Beam and Stringer grades is subject to loads causing flatwise bending or buckling, reference modulus of elasticity (E or E_{min}) shall be multiplied by the flat use factor, C_{fu}, specified in Table 4D of the NDS Supplement; otherwise, C_{fu} = 1.0.

Adjustment Factors

Allowable Flexure Stress F_b'

F_b from tables determined by species and grade

$$F_b' = F_b (C_D C_M C_t C_L C_F C_{fu} C_i C_r)$$

Usage factors for flexure:

C_D Load Duration Factor

Table 2.3.2 Frequently Used Load Duration Factors, C_D ¹

Load Duration	C_D	Typical Design Loads
Permanent	0.9	Dead Load
Ten years	1.0	Occupancy Live Load
Two months	1.15	Snow Load
Seven days	1.25	Construction Load
Ten minutes	1.6	Wind/Earthquake Load
Impact ²	2.0	Impact Load

Figure B1 Load Duration Factors, C_D , for Various Load Durations

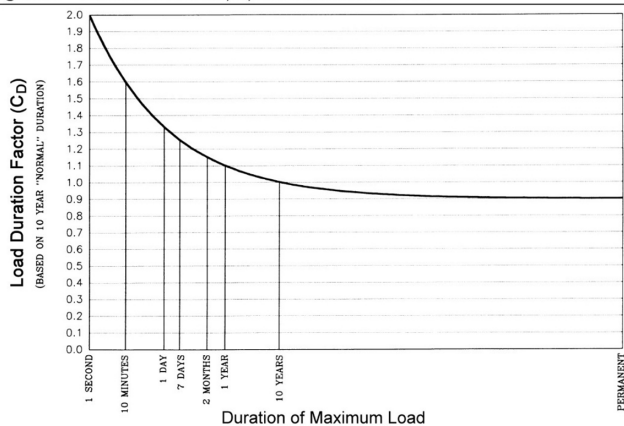

- (1) Actual stress due to (DL) $\leq (0.9)$ (Design value)
- (2) Actual stress due to (DL+LL) $\leq (1.0)$ (Design value)
- (3) Actual stress due to (DL+WL) $\leq (1.6)$ (Design value)
- (4) Actual stress due to (DL+LL+SL) $\leq (1.15)$ (Design value)
- (5) Actual stress due to (DL+LL+WL) $\leq (1.6)$ (Design value)
- (6) Actual stress due to (DL+SL+WL) $\leq (1.6)$ (Design value)
- (7) Actual stress due to (DL+LL+SL+WL) $\leq (1.6)$ (Design value)

Adjustment Factors

Allowable Flexure Stress F_b'

F_b from tables determined by species and grade

$$F_b' = F_b (C_D C_M C_t C_L C_F C_{fu} C_i C_r)$$

Usage factors for flexure:

C_t Temperature Factor

2.3.3 Temperature Factor, C_t

Reference design values shall be multiplied by the temperature factors, C_t , in Table 2.3.3 for structural members that will experience sustained exposure to elevated temperatures up to 150°F (see Appendix C).

Table 2.3.3 Temperature Factor, C_t

Reference Design Values	In-Service Moisture Conditions ¹	C_t		
		$T \leq 100^\circ\text{F}$	$100^\circ\text{F} < T \leq 125^\circ\text{F}$	$125^\circ\text{F} < T \leq 150^\circ\text{F}$
F_t, E, E_{min}	Wet or Dry	1.0	0.9	0.9
	Dry	1.0	0.8	0.7
$F_b, F_v, F_c,$ and $F_{c\perp}$	Wet	1.0	0.7	0.5

1. Wet and dry service conditions for sawn lumber, structural glued laminated timber, prefabricated wood I-joists, structural composite lumber, wood structural panels and cross-laminated timber are specified in 4.1.4, 5.1.4, 7.1.4, 8.1.4, 9.3.3, and 10.1.5 respectively.

Adjustment Factors

Allowable Flexure Stress F_b'

F_b from NDS tables

$$F_b' = F_b (C_D C_M C_t C_L C_F C_{fu} C_i C_r)$$

Usage factors for flexure:

C_M Moisture Factor (Supplement)

C_F Size Factor (Supplement)

Wet Service Factor, C_M

When dimension lumber is used where moisture content will exceed 19% for an extended time period, design values shall be multiplied by the appropriate wet service factors from the following table:

Wet Service Factors, C_M					
F_b	F_t	F_v	$F_{c\perp}$	F_c	E and E_{min}
0.85*	1.0	0.97	0.67	0.8**	0.9

* when $(F_b)(C_F) \leq 1,150$ psi, $C_M = 1.0$

** when $(F_c)(C_F) \leq 750$ psi, $C_M = 1.0$

Size Factors, C_F

Grades	Width (depth)	F_b		F_t	F_c
		Thickness (breadth)			
		2" & 3"	4"		
Select Structural, No.1 & Btr, No.1, No.2, No.3	2", 3", & 4"	1.5	1.5	1.5	1.15
	5"	1.4	1.4	1.4	1.1
	6"	1.3	1.3	1.3	1.1
	8"	1.2	1.3	1.2	1.05
	10"	1.1	1.2	1.1	1.0
	12"	1.0	1.1	1.0	1.0
Stud	14" & wider	0.9	1.0	0.9	0.9
	2", 3", & 4"	1.1	1.1	1.1	1.05
	5" & 6"	1.0	1.0	1.0	1.0
Construction, Standard	8" & wider	Use No.3 Grade tabulated design values and size factors			
	2", 3", & 4"	1.0	1.0	1.0	1.0
Utility	4"	1.0	1.0	1.0	1.0
	2" & 3"	0.4	—	0.4	0.6

Adjustment Factors

Allowable Flexure Stress F_b'

F_b from NDS tables

$$F_b' = F_b (C_D C_M C_t C_L C_F C_{fu} C_i C_r)$$

Usage factors for flexure:

- C_{fu} Flat Use (Supplement)
- C_r Repetitive Member Factor (Supplement)

Flat Use Factor, C_{fu}

Bending design values adjusted by size factors are based on edgewise use (load applied to narrow face). When dimension lumber is used flatwise (load applied to wide face), the bending design value, F_b , shall also be permitted to be multiplied by the following flat use factors:

Flat Use Factors, C_{fu}		
Width (depth)	Thickness (breadth)	
	2" & 3"	4"
2" & 3"	1.0	—
4"	1.1	1.0
5"	1.1	1.05
6"	1.15	1.05
8"	1.15	1.05
10" & wider	1.2	1.1

Repetitive Member Factor, C_r

Bending design values, F_b , for dimension lumber 2" to 4" thick shall be multiplied by the repetitive member factor, $C_r = 1.15$, when such members are used as joists, truss chords, rafters, studs, planks, decking, or similar members which are in contact or spaced not more than 24" on center, are not less than 3 in number and are joined by floor, roof, or other load distributing elements adequate to support the design load.

Adjustment Factors

Allowable Flexure Stress F_b'

F_b from tables determined by species and grade

$$F_b' = F_b (C_D C_M C_t C_L C_F C_{fu} C_i C_r)$$

Usage factors for flexure:

- C_i Incising Factor

Table 4.3.8 Incising Factors, C_i

Design Value	C_i
E_s, E_{min}	0.95
F_b, F_t, F_c, F_v	0.80
F_{cL}	1.00

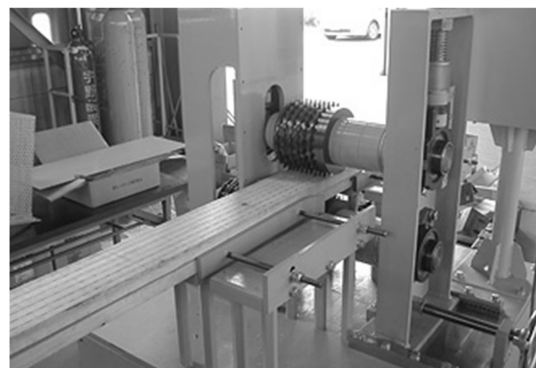

Adjustment Factors

Allowable Flexure Stress F_b'

F_b' from tables determined by species and grade

$$F_b' = F_b (C_D C_M C_t C_L C_F C_{fu} C_i C_r)$$

Usage factors for flexure:

C_L Beam Stability Factor

3.3.3 Beam Stability Factor, C_L

3.3.3.1 When the depth of a bending member does not exceed its breadth, $d \leq b$, no lateral support is required and $C_L = 1.0$.

3.3.3.2 When rectangular sawn lumber bending members are laterally supported in accordance with 4.4.1, $C_L = 1.0$.

3.3.3.3 When the compression edge of a bending member is supported throughout its length to prevent lateral displacement, and the ends at points of bearing have lateral support to prevent rotation, $C_L = 1.0$.

2012 NDS

4.4.1 Stability of Bending Members

- 2x4 (a) $d/b \leq 2$; no lateral support shall be required.
- 2x6-8 (b) $2 < d/b \leq 4$; the ends shall be held in position, as by full depth solid blocking, bridging, hangers, nailing, or bolting to other framing members, or other acceptable means.
- 2x10 (c) $4 < d/b \leq 5$; the compression edge of the member shall be held in line for its entire length to prevent lateral displacement, as by adequate sheathing or subflooring, and ends at point of bearing shall be held in position to prevent rotation and/or lateral displacement.
- 2x12 (d) $5 < d/b \leq 6$; bridging, full depth solid blocking or diagonal cross bracing shall be installed at intervals not exceeding 8 feet, the compression edge of the member shall be held in line as by adequate sheathing or subflooring, and the ends at points of bearing shall be held in position to prevent rotation and/or lateral displacement.
- 2x14 (e) $6 < d/b \leq 7$; both edges of the member should be held in line for their entire length and ends at points of bearing shall be held in position to prevent rotation and/or lateral displacement.

C_L

$C_L = 1.0$
when bracing meets 4.4.1
for the depth/width ratio

Otherwise

$C_L < 1.0$
calculate factor using
section 3.3.3

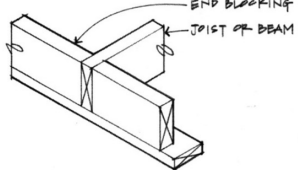
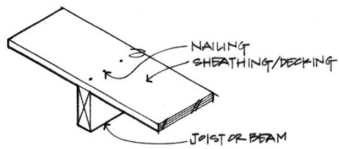
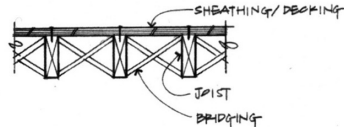
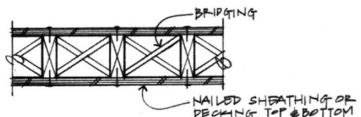
Beam Depth/ Width Ratio	Type of Lateral Bracing Required	Example
2 to 1	None	
3 to 1 2x6 2x8	The ends of the beam should be held in position	
5 to 1 2x10	Hold compression edge in line (continuously)	
6 to 1 2x12	Diagonal bridging should be used	
7 to 1 2x14	Both edges of the beam should be held in line	

C_L Beam Stability Factor

In the case bracing provisions of 4.4.1 cannot be met, C_L is calculated using equation 3.3-6

The maximum allowable slenderness, R_B is 50

Table 3.3.3 Effective Length, ℓ_e, for Bending Members

Cantilever ¹	when ℓ _e /d < 7	when ℓ _e /d ≥ 7
Uniformly distributed load	ℓ _e =1.33 ℓ _u	ℓ _e =0.90 ℓ _u + 3d
Concentrated load at unsupported end	ℓ _e =1.87 ℓ _u	ℓ _e =1.44 ℓ _u + 3d
Single Span Beam ^{1,2}	when ℓ _e /d < 7	when ℓ _e /d ≥ 7
Uniformly distributed load	ℓ _e =2.06 ℓ _u	ℓ _e =1.63 ℓ _u + 3d
Concentrated load at center with no intermediate lateral support	ℓ _e =1.80 ℓ _u	ℓ _e =1.37 ℓ _u + 3d
Concentrated load at center with lateral support at center	ℓ _e =1.11 ℓ _u	
Two equal concentrated loads at 1/3 points with lateral support at 1/3 points	ℓ _e =1.68 ℓ _u	
Three equal concentrated loads at 1/4 points with lateral support at 1/4 points	ℓ _e =1.54 ℓ _u	
Four equal concentrated loads at 1/5 points with lateral support at 1/5 points	ℓ _e =1.68 ℓ _u	
Five equal concentrated loads at 1/6 points with lateral support at 1/6 points	ℓ _e =1.73 ℓ _u	
Six equal concentrated loads at 1/7 points with lateral support at 1/7 points	ℓ _e =1.78 ℓ _u	
Seven or more equal concentrated loads, evenly spaced, with lateral support at points of load application	ℓ _e =1.84 ℓ _u	
Equal end moments	ℓ _e =1.84 ℓ _u	

1. For single span or cantilever bending members with loading conditions not specified in Table 3.3.3:
 ℓ_e = 2.06 ℓ_u when ℓ_e/d < 7
 ℓ_e = 1.63 ℓ_u + 3d when 7 ≤ ℓ_e/d ≤ 14.3
 ℓ_e = 1.84 ℓ_u when ℓ_e/d > 14.3
 2. Multiple span applications shall be based on table values or engineering analysis.

3.3.3.6 The slenderness ratio, R_B, for bending members shall be calculated as follows:

$$R_B = \sqrt{\frac{\ell_e d}{b^2}} \quad (3.3-5)$$

3.3.3.7 The slenderness ratio for bending members, R_B, shall not exceed 50.

3.3.3.8 The beam stability factor shall be calculated as follows:

$$C_L = \frac{1 + (F_{BE}/F_b^*)}{1.9} - \sqrt{\left[\frac{1 + (F_{BE}/F_b^*)}{1.9} \right]^2 - \frac{F_{BE}/F_b^*}{0.95}} \quad (3.3-6)$$

where:

F_b^{*} = reference bending design value multiplied by all applicable adjustment factors except C_{tu}, C_v (when C_v ≤ 1.0), and C_L (see 2.3), psi

$$F_{BE} = \frac{1.20 E_{min}'}{R_B^2}$$

Adjustment Factors for Shear

Allowable Flexure Stress F_v'

F_v from tables determined by species and grade

F_v' = F_v (usage factors)

Usage factors for shear:

- C_D Load Duration Factor
- C_M Moisture Factor
- C_t Temperature Factor
- C_i Incising Factor

Shear at Supports

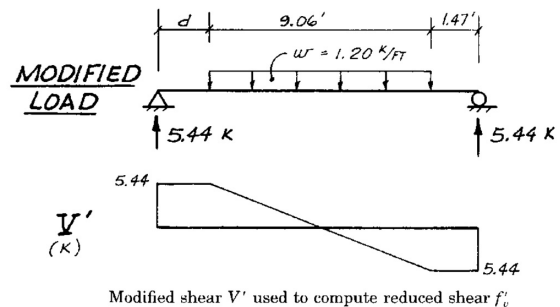
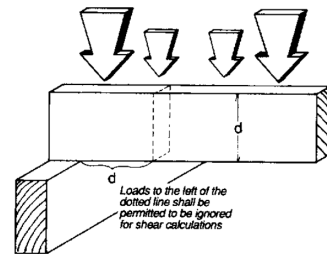

Analysis Procedure

Given: loading, member size, material and span.

Req'd: Safe or Unsafe (Pass/Fail)

1. Find Max Shear & Moment

- Simple case – equations
- Complex case - diagrams

2. Determine actual stresses

- $f_b = M/S$
- $f_v = 1.5 V/A$

3. Determine allowable stresses

- F_b and F_v (from NDS)
- $F_b' = F_b$ (usage factors)
- $F_v' = F_v$ (usage factors)

4. Check that actual \leq factored allowable

- $f_b \leq F_b'$
- $f_v \leq F_v'$

5. Check deflection < building code max.

6. Check bearing ($F_{cL} \geq \text{Reaction}/A_{\text{bearing}}$)

Nominal Size b x d	Standard Dressed Size (\$S4S) b x d in. x in.	Area of Section A in. ²	X-X AXIS		Y-Y AXIS	
			Section Modulus S_{xx} in. ³	Moment of Inertia I_{xx} in. ⁴	Section Modulus S_{yy} in. ³	Moment of Inertia I_{yy} in. ⁴
Boards¹						
1 x 3	3/4 x 2-1/2	1.875	0.781	0.977	0.234	0.088
1 x 4	3/4 x 3-1/2	2.625	1.531	2.680	0.328	0.123
1 x 6	3/4 x 5-1/2	4.125	3.781	10.40	0.516	0.193
1 x 8	3/4 x 7-1/4	5.438	6.570	23.82	0.680	0.255
1 x 10	3/4 x 9-1/4	6.938	10.70	49.47	0.867	0.325
1 x 12	3/4 x 11-1/4	8.438	15.82	88.99	1.055	0.396
Dimension Lumber (see NDS 4.1.3.2) and Decking (see NDS 4.1.3.5)						
2 x 3	1-1/2 x 2-1/2	3.750	1.56	1.953	0.938	0.703
2 x 4	1-1/2 x 3-1/2	5.250	3.06	5.359	1.313	0.984
2 x 5	1-1/2 x 4-1/2	6.750	5.06	11.39	1.688	1.266
2 x 6	1-1/2 x 5-1/2	8.250	7.56	20.80	2.063	1.547
2 x 8	1-1/2 x 7-1/4	10.88	13.14	47.63	2.719	2.039
2 x 10	1-1/2 x 9-1/4	13.88	21.39	98.93	3.469	2.602
2 x 12	1-1/2 x 11-1/4	16.88	31.64	178.0	4.219	3.164
2 x 14	1-1/2 x 13-1/4	19.88	43.89	290.8	4.969	3.727
3 x 4	2-1/2 x 3-1/2	8.75	5.10	8.932	3.646	4.557
3 x 5	2-1/2 x 4-1/2	11.25	8.44	18.98	4.688	5.859
3 x 6	2-1/2 x 5-1/2	13.75	12.60	34.66	5.729	7.161
3 x 8	2-1/2 x 7-1/4	18.13	21.90	79.39	7.552	9.440
3 x 10	2-1/2 x 9-1/4	23.13	35.65	164.9	9.635	12.04
3 x 12	2-1/2 x 11-1/4	28.13	52.73	296.6	11.72	14.65
3 x 14	2-1/2 x 13-1/4	33.13	73.15	484.6	13.80	17.25
3 x 16	2-1/2 x 15-1/4	38.13	96.90	738.9	15.89	19.86
4 x 4	3-1/2 x 3-1/2	12.25	7.15	12.51	7.146	12.51
4 x 5	3-1/2 x 4-1/2	15.75	11.81	26.58	9.188	16.08
4 x 6	3-1/2 x 5-1/2	19.25	17.65	48.53	11.23	19.65
4 x 8	3-1/2 x 7-1/4	25.38	30.66	111.1	14.80	25.90
4 x 10	3-1/2 x 9-1/4	32.38	49.91	230.8	18.89	33.05
4 x 12	3-1/2 x 11-1/4	39.38	73.83	415.3	22.97	40.20
4 x 14	3-1/2 x 13-1/4	46.38	102.41	678.5	27.05	47.34
4 x 16	3-1/2 x 15-1/4	53.38	135.66	1034	31.14	54.49

from NDS 2012

Analysis Example (pass/fail)

Given:

DATASET: 1 -2-	
Span A	17 FT
Span B	11 FT
Joist O.C. Spacing	16 IN
Wood Density	45 PCF
Joist Size	2x10 NOMINAL
Beam Size	6x16 NOMINAL
Floor DL (not including joist)	3 PSF
Occupancy or Use	assembly area - fixed seats

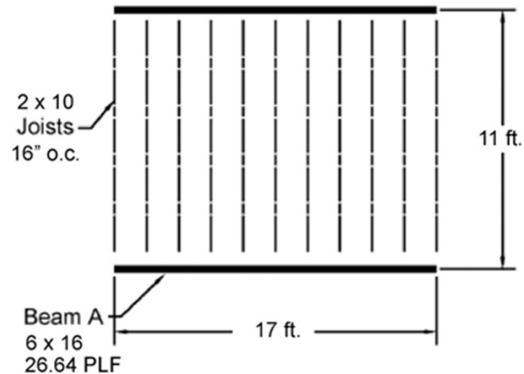

Req'd: pass or fail for floor joist



ASCE-7 Table 4.3-1: Live Load = 60 PSF

ASCE-7 2.4.1 ASD load case: D + L

2x10 Joist + floor load:

$$\begin{aligned}
 & D + L \\
 & \left(\text{SELF WEIGHT} + D \frac{\text{o.c.}}{12} \right) + \left(L \frac{\text{o.c.}}{12} \right) \\
 & \left(4.336 \text{ PLF} + 3 \text{ PSF} \frac{16''}{12} \right) + \left(60 \text{ PSF} \frac{16''}{12} \right) \\
 & 8.336 \text{ PLF} + 80 \text{ PLF} = 88.336 \text{ PLF}
 \end{aligned}$$

Analysis Example (pass/fail)

ASCE-7 Table 4.3-1: Live Load = 60 PSF

ASCE-7 2.4.1 ASD load case: D + L

2x10 Joist + floor load:

Given:

DATASET: 1 -2-	
Span A	17 FT
Span B	11 FT
Joist O.C. Spacing	16 IN
Wood Density	45 PCF
Joist Size	2x10 NOMINAL
Beam Size	6x16 NOMINAL
Floor DL (not including joist)	3 PSF
Occupancy or Use	assembly area - fixed seats

$$D + L$$

$$\left(\text{SELF WEIGHT} + D \frac{O.C.}{12} \right) + \left(L \frac{O.C.}{12} \right)$$

$$\left(4.336 \text{ PLF} + 3 \text{ PSF} \frac{16''}{12} \right) + \left(60 \text{ PSF} \frac{16''}{12} \right)$$

$$8.336 \text{ PLF} + 80 \text{ PLF} = 88.336 \text{ PLF}$$

Table 1B Section Properties of Standard Dressed (S4S) Sawn Lumber

Nominal Size b x d	Standard Dressed Size (S4S) b x d in. x in.	Area of Section A in. ²	X-X AXIS		Y-Y AXIS		Approximate weight in pounds per linear foot (lbs/ft) of piece when density of wood equals:					
			Section Modulus S _{xx} in. ³	Moment of Inertia I _{xx} in. ⁴	Section Modulus S _{yy} in. ³	Moment of Inertia I _{yy} in. ⁴	25 lbs/ft ³	30 lbs/ft ³	35 lbs/ft ³	40 lbs/ft ³	45 lbs/ft ³	50 lbs/ft ³
Dimension Lumber (see NDS 4.1.3.2) and Decking (see NDS 4.1.3.5)												
2 x 3	1-1/2 x 2-1/2	3.750	1.56	1.953	0.938	0.703	0.651	0.781	0.911	1.042	1.172	1.302
2 x 4	1-1/2 x 3-1/2	5.250	3.06	5.359	1.313	0.984	0.911	1.094	1.276	1.458	1.641	1.823
2 x 5	1-1/2 x 4-1/2	6.750	5.06	11.39	1.688	1.266	1.172	1.406	1.641	1.875	2.109	2.344
2 x 6	1-1/2 x 5-1/2	8.250	7.56	20.80	2.063	1.547	1.432	1.719	2.005	2.292	2.578	2.865
2 x 8	1-1/2 x 7-1/4	10.88	13.14	47.63	2.719	2.039	1.888	2.266	2.643	3.021	3.398	3.776
2 x 10	1-1/2 x 9-1/4	13.88	21.39	98.93	3.469	2.602	2.409	2.891	3.372	3.854	4.336	4.818
2 x 12	1-1/2 x 11-1/4	16.88	31.64	178.0	4.219	3.164	2.930	3.516	4.102	4.688	5.273	5.859
2 x 14	1-1/2 x 13-1/4	19.88	43.89	290.8	4.969	3.727	3.451	4.141	4.831	5.521	6.211	6.901

Analysis Example (pass/fail)

1. Find Max Shear & Moment on Joist

By equations:

Shear:

$$\frac{wl}{2} = \frac{88.336 (11)}{2} = 485.848 \text{ lbs}$$

Moment:

$$\frac{wl^2}{8} = \frac{88.336 (11^2)}{8} = 1336.08 \text{ ft-lbs}$$

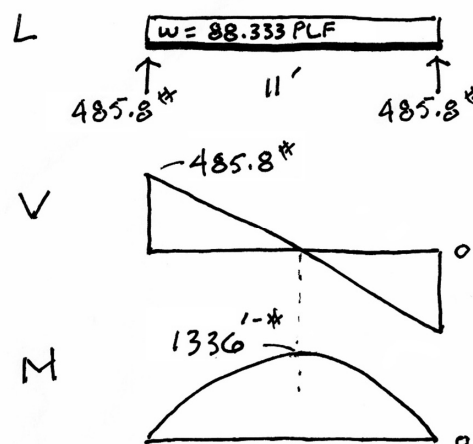

Analysis Example (pass/fail)

2. Determine actual stresses in joists

- $f_b = M/S$
- $f_v = 1.5 V/A$

$$f_b = \frac{M}{S_x} = \frac{1336 \text{ ft} \cdot \text{lb} (12)}{21.39 \text{ in}^3} = 749.5 \text{ psi}$$

$$f_v = \frac{3}{2} \frac{V}{A} = \frac{1.5 (485.8) \text{ lb}}{13.88 \text{ in}^2} = 52.5 \text{ psi}$$

Table 1B Section Properties of Standard Dressed (S4S) Sawn Lumber

Nominal Size b x d	Standard Dressed Size (S4S) b x d in. x in.	Area of Section A in. ²	X-X AXIS		Y-Y AXIS		Approximate weight in pounds per linear foot (lbs/ft) of piece when density of wood equals:					
			Section Modulus S _{xx} in. ³	Moment of Inertia I _{xx} in. ⁴	Section Modulus S _{yy} in. ³	Moment of Inertia I _{yy} in. ⁴	25 lbs/ft ³	30 lbs/ft ³	35 lbs/ft ³	40 lbs/ft ³	45 lbs/ft ³	50 lbs/ft ³
Dimension Lumber (see NDS 4.1.3.2) and Decking (see NDS 4.1.3.5)												
2 x 3	1-1/2 x 2-1/2	3.750	1.56	1.953	0.938	0.703	0.651	0.781	0.911	1.042	1.172	1.302
2 x 4	1-1/2 x 3-1/2	5.250	3.06	5.359	1.313	0.984	0.911	1.094	1.276	1.458	1.641	1.823
2 x 5	1-1/2 x 4-1/2	6.750	5.06	11.39	1.688	1.266	1.172	1.406	1.641	1.875	2.109	2.344
2 x 6	1-1/2 x 5-1/2	8.250	7.56	20.80	2.063	1.547	1.432	1.719	2.005	2.292	2.578	2.865
2 x 8	1-1/2 x 7-1/4	10.88	13.14	47.63	2.719	2.039	1.888	2.266	2.643	3.021	3.398	3.776
2 x 10	1-1/2 x 9-1/4	13.88	21.39	98.93	3.469	2.602	2.409	2.891	3.372	3.854	4.336	4.818
2 x 12	1-1/2 x 11-1/4	16.88	31.64	178.0	4.219	3.164	2.930	3.516	4.102	4.688	5.273	5.859
2 x 14	1-1/2 x 13-1/4	19.88	43.89	290.8	4.969	3.727	3.451	4.141	4.831	5.521	6.211	6.901

Analysis Example (pass/fail)

3. Determine allowable stresses – NDS Supplement

- $F_b = 875 \text{ psi}$
- $F_v = 135 \text{ psi}$



Species and Grade

Table 4A Reference Design Values for Visually Graded Dimension Lumber (2" - 4" thick)^{1,2,3}

(All species except Southern Pine— see Table 4B) (Tabulated design values are for normal load duration and dry service conditions. See NDS 4.3 for a comprehensive description of design value adjustment factors.)

USE WITH TABLE 4A ADJUSTMENT FACTORS

Species and commercial grade	Size classification	Design values in pounds per square inch (psi)						Modulus of Elasticity		Specific Gravity ⁴ G	Grading Rules Agency
		Bending F _b	Tension parallel to grain F _t	Shear parallel to grain F _v	Compression perpendicular to grain F _{c⊥}	Compression parallel to grain F _c	Modulus of Elasticity				
							E	E _{min}			
SPRUCE-PINE-FIR											
Select Structural		1,250	700	135	425	1,400	1,500,000	550,000			
No. 1/ No. 2	2" & wider	875	450	135	425	1,150	1,400,000	510,000			
No. 3		500	250	135	425	650	1,200,000	440,000			
Stud	2" & wider	675	350	135	425	725	1,200,000	440,000	0.42	NLGA	
Construction		1,000	500	135	425	1,400	1,300,000	470,000			
Standard	2" - 4" wide	550	275	135	425	1,150	1,200,000	440,000			
Utility		275	125	135	425	750	1,100,000	400,000			

Analysis Example (pass/fail)



- Determine allowable stresses – NDS Supplement
 - Adjustment Factors

Determine factors:

- CD = ?
- CM = 1
- Ct = 1
- CL = ?
- CF = ?
- Cfu = 1
- Ci = 1
- Cr = ?

Table 4.3.1 Applicability of Adjustment Factors for Sawn Lumber

		ASD only	ASD and LRFD										LRFD only		
		Load Duration Factor	Wet Service Factor	Temperature Factor	Beam Stability Factor	Size Factor	Flat Use Factor	Incising Factor	Repetitive Member Factor	Column Stability Factor	Buckling Stiffness Factor	Bearing Area Factor	Format Conversion Factor	Resistance Factor	Time Effect Factor
$F_b' = F_b$	x	C _D	C _M	C _t	C _L	C _F	C _{fu}	C _i	C _r	-	-	-	K _F	φ _b	λ
$F_v' = F_v$	x	C _D	C _M	C _t	-	-	-	C _i	-	-	-	-	K _F	φ _v	λ

Analysis Example (pass/fail)

Table 2.3.2 Frequently Used Load Duration Factors, C_D¹

C_D Load duration factor
Occupancy LL (10 years) = 1.0

Load Duration	C _D	Typical Design Loads
Permanent	0.9	Dead Load
Ten years	1.0	Occupancy Live Load
Two months	1.15	Snow Load
Seven days	1.25	Construction Load
Ten minutes	1.6	Wind/Earthquake Load
Impact ²	2.0	Impact Load

C_F Size factor

2 x 10
use 1.1

Size Factors, C_F

Grades	Width (depth)	F _b		F _t	F _c
		Thickness (breadth)			
		2" & 3"	4"		
Select Structural, No.1 & Btr, No.1, No.2, No.3	2", 3", & 4"	1.5	1.5	1.5	1.15
	5"	1.4	1.4	1.4	1.1
	6"	1.3	1.3	1.3	1.1
	8"	1.2	1.3	1.2	1.05
	10"	1.1	1.2	1.1	1.0
	12"	1.0	1.1	1.0	1.0
Stud	14" & wider	0.9	1.0	0.9	0.9
	2", 3", & 4"	1.1	1.1	1.1	1.05
	5" & 6"	1.0	1.0	1.0	1.0
Construction, Standard	2", 3", & 4"	Use No.3 Grade tabulated design values and size factors			
		1.0	1.0	1.0	1.0
Utility	4"	1.0	1.0	1.0	1.0
	2" & 3"	0.4	—	0.4	0.6

Analysis Example (pass/fail)

C_r Repetitive Member Factor

16" o.c. : $C_r = 1.15$

Repetitive Member Factor, C_r

Bending design values, F_b , for dimension lumber 2" to 4" thick shall be multiplied by the repetitive member factor, $C_r = 1.15$, when such members are used as joists, truss chords, rafters, studs, planks, decking, or similar members which are in contact or spaced not more than 24" on center, are not less than 3 in number and are joined by floor, roof, or other load distributing elements adequate to support the design load.

Analysis Example (pass/fail)

C_L Beam Stability Factor

2x10 w/ flooring: $C_L = 1.0$

$C_L = 1.0$
if depth/width ratio meets criteria
in 4.4.1 $C_L = 1.0$

Otherwise:

$C_L < 1.0$
calculate factor using section 3.3.3

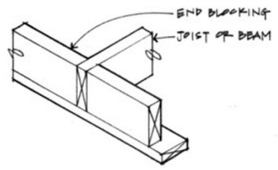
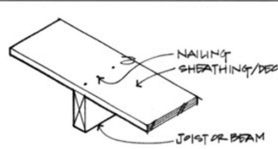
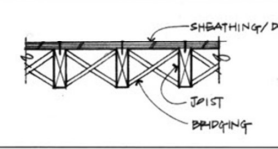
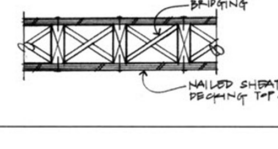
Beam Depth/ Width Ratio	Type of Lateral Bracing Required	Example
2 to 1	None	
3 to 1 2x6 2x8	The ends of the beam should be held in position	
5 to 1 2x10	Hold compression edge in line (continuously)	
6 to 1 2x12	Diagonal bridging should be used	
7 to 1 2x14	Both edges of the beam should be held in line	

Analysis Example (pass/fail)

3. Determine factored allowable stresses

- $F'_b = F_b (C_D)(C_L)(C_F)(C_r)$
- $F'_b = 875 (1.0) (1.0) (1.1) (1.15) = 1107 \text{ psi}$
- $F'_v = F_v (C_D)$
- $F'_v = 135 (1.0) = 135 \text{ psi}$

4. Check that actual \leq factored allowable

- $f_b < F'_b \quad 749.5 < 1107$
- $f_v < F'_v \quad 52.5 < 135$

$$f_b = \frac{M}{S_x} = \frac{1336' \cdot (12)}{21.39 \text{ in}^3} = 749.5 \text{ psi}$$

$$f_v = \frac{3}{2} \frac{V}{A} = \frac{1.5 (485.8)'}{13.88 \text{ in}^2} = 52.5 \text{ psi}$$

5. Check deflection

6. Check bearing ($F_{cp} = R/A_b$)

Analysis Example (pass/fail)

5. Check deflection < Code limits

- NDS 3.5
- Δ_{LT} - Long term
- Δ_{ST} - Short term
- K_{cr} - creep factor

$$\Delta_T = K_{cr} \Delta_{LT} + \Delta_{ST} \quad (\text{NDS 3.5-1})$$

K_{cr}

- 1.5 dry, seasoned lumber
- 2.0 wet service conditions
- 2.0 wood panels
- 2.0 CLT (dry)

TABLE 1604.3 DEFLECTION LIMITS^{a, b, c, h, i}

CONSTRUCTION	L	S or W ^d	D + L ^{d, g}
Roof members: ^e			
Supporting plaster or stucco ceiling	//360	//360	//240
Supporting nonplaster ceiling	//240	//240	//180
Not supporting ceiling	//180	//180	//120
Floor members	//360	—	//240
Exterior walls:			
With plaster or stucco finishes	—	//360	—
With other brittle finishes	—	//240	—
With flexible finishes	—	//120	—
Interior partitions: ^b			
With plaster or stucco finishes	//360	—	—
With other brittle finishes	//240	—	—
With flexible finishes	//120	—	—
Farm buildings	—	—	//180
Greenhouses	—	—	//120

Δ_{ST}

$$\Delta_L = \frac{5wL^4}{384EI} = \frac{5(80 \text{ PLF})(11 \text{ FT})^4 (1728)}{384(1400000 \text{ PSI})(98.93 \text{ IN}^4)}$$

$$\Delta_L = 0.19''$$

$$\frac{P}{360} = \frac{11 \text{ FT}(12)}{360} = 0.367''$$

Δ_{LT}

$$\Delta_D = \frac{5wL^4}{384EI} = \frac{5(8.34 \text{ PLF})(11 \text{ FT})^4 (1728)}{384(1400000 \text{ PSI})(98.93 \text{ IN}^4)}$$

$$\Delta_D = 0.02''$$

$$K_{cr} = 1.5$$

$$\Delta_T = K_{cr} \Delta_{LT} + \Delta_{ST}$$

$$= 1.5(0.02) + 0.19 = 0.22''$$

$$\frac{P}{240} = \frac{11 \text{ FT}(12)}{240} = 0.55''$$

Analysis Example (pass/fail)

6. Check bearing : $F_{c\perp} < P/A_b$

$$F_{c\perp} = 425 \text{ psi}$$

$$P = R = 485.8 \text{ lbs}$$

$$A_b = 1.5'' (1'') = 1.5 \text{ in}^2$$

$$f_b = \frac{485.8}{1.5} = 323.8 \text{ psi} < 425 \text{ psi} \quad \text{ok}$$

3.10.4 Bearing Area Factor, C_b

Reference compression design values perpendicular to grain, $F_{c\perp}$, apply to bearings of any length at the ends of a member, and to all bearings 6" or more in length at any other location. For bearings less than 6" in length and not nearer than 3" to the end of a member, the reference compression design value perpendicular to grain, $F_{c\perp}$, shall be permitted to be multiplied by the following bearing area factor, C_b :

$$C_b = \frac{\ell_b + 0.375}{\ell_b} \quad (3.10-2)$$

where:

ℓ_b = bearing length measured parallel to grain, in.

Equation 3.10-2 gives the following bearing area factors, C_b , for the indicated bearing length on such small areas as plates and washers:

Table 3.10.4 Bearing Area Factors, C_b

ℓ_b	0.5"	1"	1.5"	2"	3"	4"	6" or more
C_b	1.75	1.38	1.25	1.19	1.13	1.10	1.00

For round bearing areas such as washers, the bearing length, ℓ_b , shall be equal to the diameter.