

## Composite Sections (Steel Beam + Conc. Slab)

- Composite Sections by LRFD
- Analysis Methods



Photo by Mike Greenwood, 2009. Used with permission

## Composite Design

Steel W section with concrete slab  
“attached” by shear studs.

The concrete slab acts as a wider and  
thicker compression flange.

Strength increase by 33% to 50%

Deflection reduced by 70% to 80%

Can attain either longer spans or smaller  
members – more economical in long spans

Smaller floor depth, therefore reduced  
overall building heights and weights

Reduced DL of system, reduction of other  
material vertically (façade, walls, plumbing,  
wiring, etc.)



# Shear Studs

Also called Nelson studs after the company that originated them.



From AISC DigiLib

Can be spot welded through light gage decking onto W section

## Effective Flange Width, $b_{eff}$

Slab on both sides:

$b_e$  is the least total width :

- Total width:  $\frac{1}{4}$  of the beam span
- Overhang: 8 x slab thickness
- Overhang:  $\frac{1}{2}$  the clear distance to next beam (i.e.  $b_e$  is the web on center spacing)

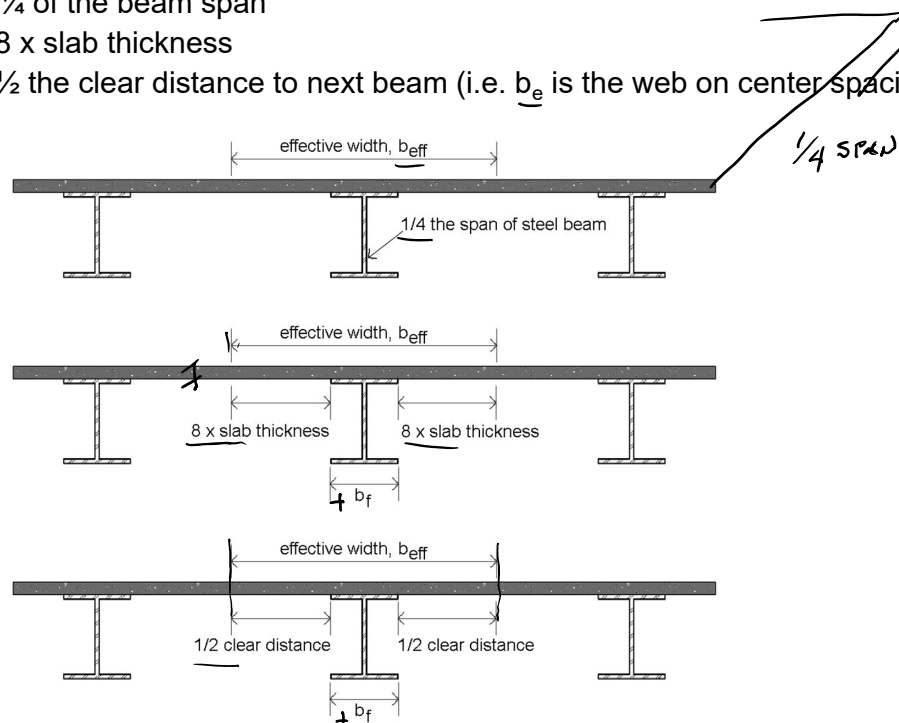

# Effective Flange Width, $b_e$

## Slab on one side:

$b_e$  is the **least** total width (i.e. overhang + steel flange) :

- Total width:  $\frac{1}{12}$  of the beam span
- Overhang:  $6 \times$  slab thickness
- Overhang:  $\frac{1}{2}$  the clear distance to next beam

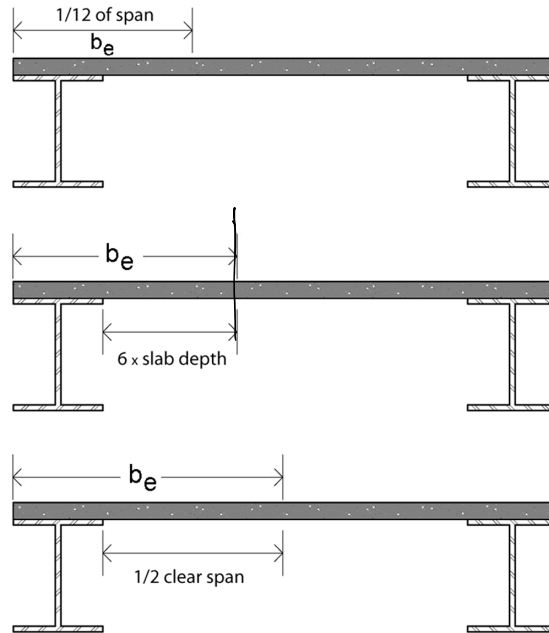

## Analysis Procedure (LRFD)

Case 1 – Plastic Neutral Axis (PNA) within slab

Case 2 – PNA within steel section

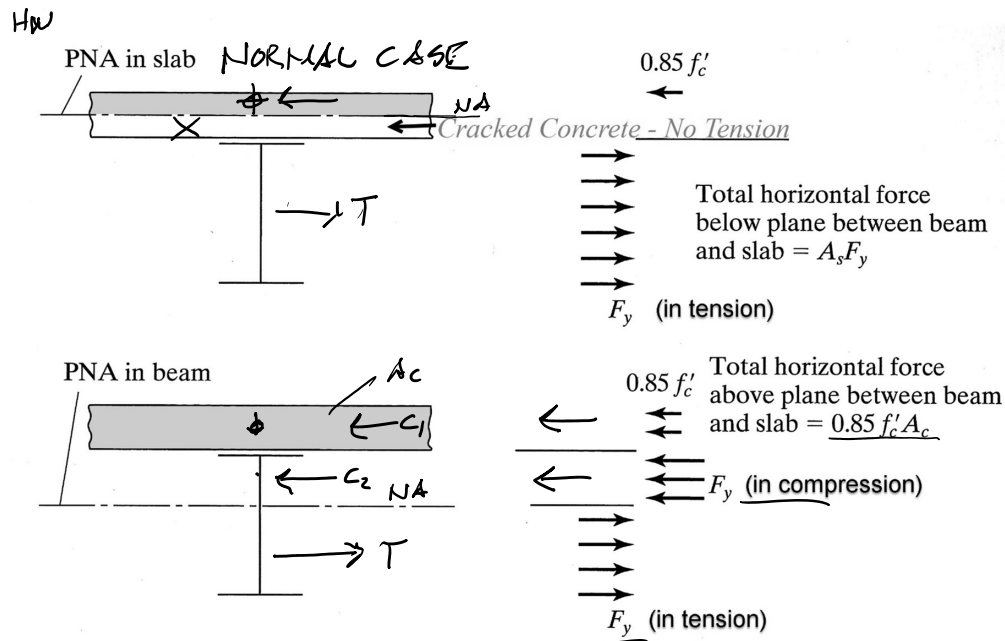

# Analysis Procedure (LRFD)

## Case1 – PNA within slab

Given: Slab and beam geometry  
W-section size and steel grade  
(floor loads)

Find: pass/fail or capacities

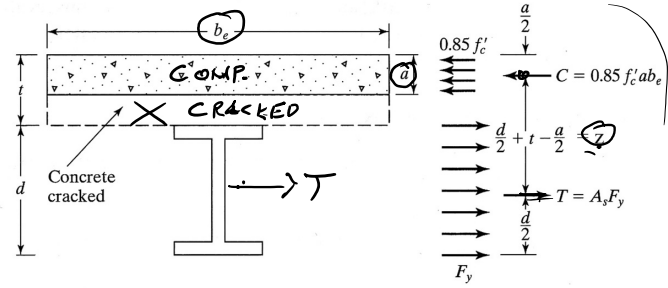

1. Define effective flange width,  $b_e$
2. Calculate the effective depth of the concrete stress block,  $a$

3. If  $a$  is within concrete slab, the full steel section is in tension and:

$$\frac{M_p}{M_n} = \frac{T z}{M_p} = A_s F_y (d/2 + t - a/2)$$

$$T = C$$

$$A_s f_y = 0.85 f'_c a b_e$$

$$a = \frac{A_s f_y}{0.85 f'_c b_e}$$

4.  $M_u \leq \phi M_n$

## Non-composite vs. Composite Sections

Given:

- $DL_{slab} = 62.5 \text{ psf} = 812.5 \text{ plf}$
- $DL_{beam} = 99 \text{ plf}$
- $LL = ?$
- W 30x99 ✓
- $F_y = 50 \text{ ksi}$
- $f'_c_{conc} = 4 \text{ ksi}$

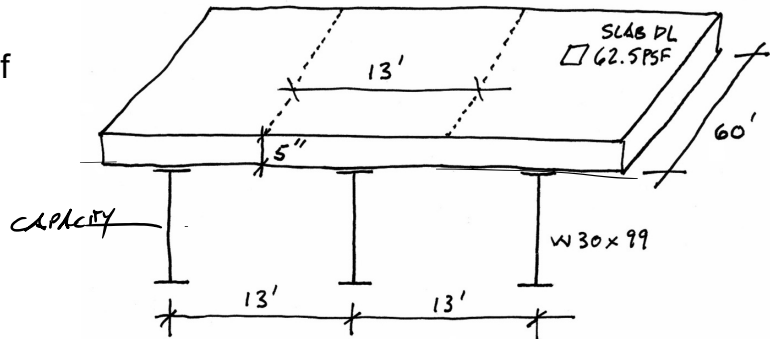

Find: Load Capacity

For this example, floor capacity is found for two different floor systems:

1. Find capacity of steel section independent from slab

vs.

2. Find capacity of steel and slab as a composite section

WEIGHT of SLAB

$$\frac{5''}{12} 150 \text{ PCF} = 62.5 \text{ PSF}$$

$$13' \times 62.5 \text{ PSF} = 812.5 \text{ PLF}$$

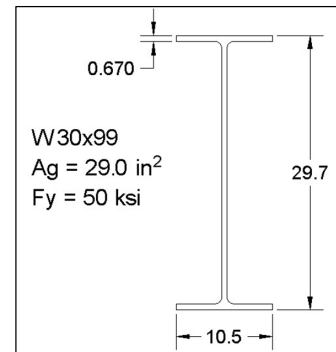

# Part 1 Non-composite Capacity Analysis

(Example part 1 - steel beam alone - LRFD)

WEIGHT of SLAB

$$-\frac{5''}{12} \cdot 150 \text{ PCF} = 62.5 \text{ PSF}$$

$$13' \times 62.5 \text{ PSF} = 812.5 \text{ PLF}$$

Given:

- $DL_{\text{slab}} = 62.5 \text{ psf} = 812.5 \text{ plf}$
- $DL_{\text{beam}} = 99 \text{ plf}$
- W 30x99

1. Find section modulus,  $Z_x$  in the steel W-section chart.
2. Calculate  $M_n = F_y Z_x$ .
3.  $M_u \leq \phi M_n$
4. Find  $w_u$  from moment equation
5. Subtract the DL to find the remaining LL.
6. Calculate LL capacity in PSF.

W30x99  $Z_x = 312 \text{ in}^2$

$$M_n = F_y Z_x = 50(312) = 15600 \text{ ''-K}$$

$$= 1300 \text{ ''-K} = M_n$$

$$\phi M_n = M_u = 0.9(1300) = 1170 \text{ ''-K}$$

$$M_u = \frac{w_u l^2}{8} = \frac{w_u (60)^2}{8} = 1170 \text{ ''-K}$$

$$w_u = 2.6 \text{ KLF} = 2600 \text{ PLF}$$

$$w_u = 1.2(w_{DL}) + 1.6(w_{LL}) = 2600 \text{ PLF}$$

$$w_u = 1.2(812.5 + 99) + 1.6(w_{LL}) = 2600 \text{ PLF}$$

$$w_{LL} = 941.3 \text{ PLF}$$

$$LL = 941.3 \text{ PLF} / 13' = 72.4 \text{ PSF}$$

## Composite Analysis Procedure

(Case1 – PNA within slab)

Given: Slab and beam geometry  
W-section size and steel grade  
(floor loads)

Find: pass/fail or capacities

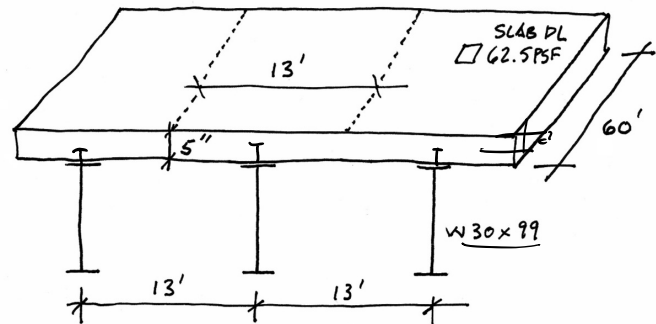

1. Determine effective flange width ( $b_e$ )
2. Calculate the effective depth of the concrete stress block,  $a$
3. If  $a$  is within concrete slab, the full steel section is in tension and:  
 $M_n = M_p = A_s F_y (d/2 + t - a/2)$
4.  $M_u \leq \phi M_n$
5. Use  $M_u$  to calculate factored loads with appropriate beam moment equation.

WEIGHT of SLAB

$$\frac{5''}{12} \cdot 150 \text{ PCF} = 62.5 \text{ PSF}$$

$$13' \times 62.5 \text{ PSF} = 812.5 \text{ PLF}$$

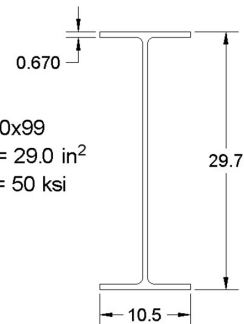

W30x99

$A_g = 29.0 \text{ in}^2$

$F_y = 50 \text{ ksi}$

# Composite Capacity Analysis

(Example part 2 - composite steel beam and slab)

Given:

- $DL_{slab} = 62.5 \text{ psf} = 812.5 \text{ plf}$
- $DL_{beam} = 99 \text{ plf}$
- $LL = ?$
- W 30x99
- $F_y = 50 \text{ ksi}$
- $f'_c_{conc} = 4 \text{ ksi}$

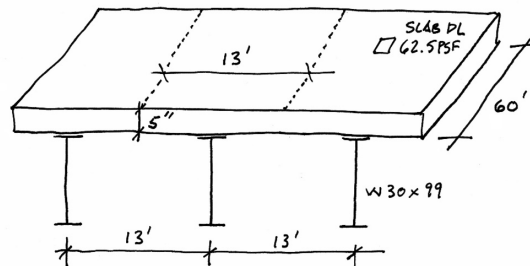

Find:

capacity of steel and slab as a composite section

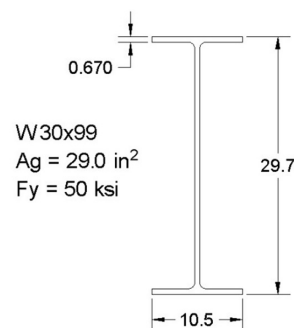

## Part 2 Composite Capacity Analysis

1. Determine effective flange width,  $b_e$

$b_e$  is the **least** total width :

- Total width:  $\frac{1}{4}$  of the beam span
- Overhang: 8 x slab thickness
- Overhang:  $\frac{1}{2}$  the clear distance to next beam (i.e.  $b_e$  is the web on center spacing)

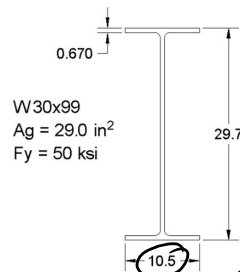
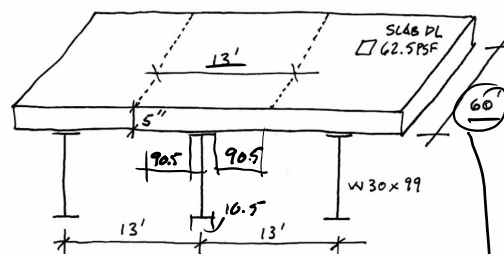
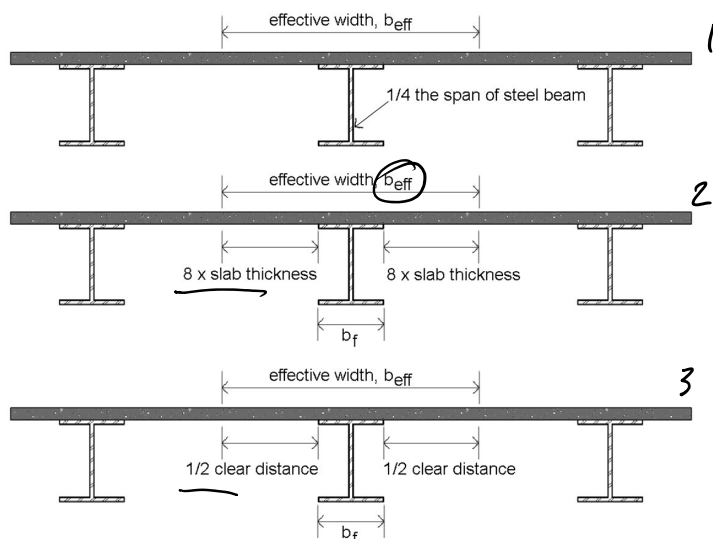

$b_e$  is the **least** total width :

$$b_e \text{ ①} = \frac{1}{4} 60' = 15' = 180''$$

$$b_e \text{ ②} = 8(5'') \times 2 + 10.5 = 90.5''$$

$$b_e \text{ ③} = 13' = 156''$$

$$\therefore b_e = 90.5''$$

# Part 2 - Composite Capacity Analysis cont.

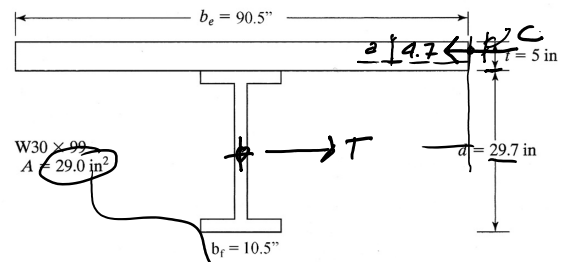
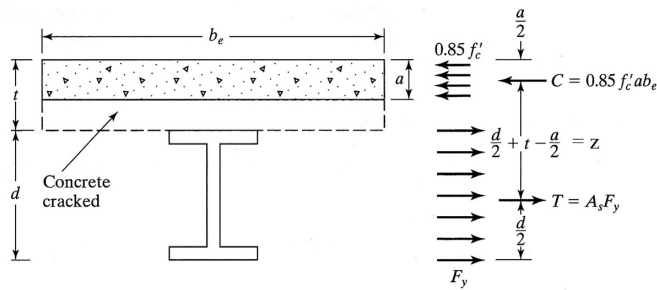

2. Calculate the effective depth of the concrete stress block, a

$$a = \frac{A_s F_y}{0.85 f'_c b_e} = \frac{29.0(50)}{0.85(4)(90.5)} = 4.712''$$

4.712" < 5" ∴ WITHIN SLAB

3. If a is within concrete slab, the full steel section is in tension and:

$$M_n = M_p = A_s F_y (d/2 + t - a/2)$$

$$M_n = M_p = T \times z$$

$$M_n = A_s F_y \left( \frac{d}{2} + t - \frac{a}{2} \right)$$

$$M_n = 29.0 \text{ in}^2 (50 \text{ ksi}) \left( \frac{29.7}{2} + 5 - \frac{4.712}{2} \right)$$

$$M_n = 25366 \text{ in-k} = 2114 \text{ ft-k}$$

$$\phi M_n = 0.9(2114) = 1902 \text{ ft-k} = M_u$$

4.  $M_u \leq \phi M_n$

# Composite Analysis cont.

4.  $M_u \leq \phi M_n$

5. Find total factored  $w_u$ .

6. Subtract the factored  $w_{DL}$  to find  $w_{LL}$ .

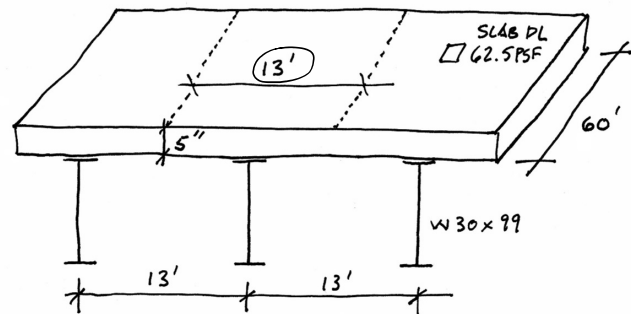

WEIGHT of SLAB

$$\frac{5''}{12} 150 \text{ PCF} = 62.5 \text{ PSF}$$

$$13' \times 62.5 \text{ PSF} = 812.5 \text{ PLF}$$

7. Calculate the LL in PSF based on the  $w_{LL}$ .

$$M_u = 1902 = \frac{w_u l^2}{8} = \frac{w_u 60^2}{8}$$

$$w_u = 4,227 \text{ PLF} = 1.2(w_{DL}) + 1.6(w_{LL})$$

$$w_u = 4227 \text{ PLF} = 1.2(911.5) + 1.6(w_{LL})$$

$$w_{LL} = 1958 \text{ PLF}$$

$$LL = 1958 \text{ PLF} / 13' = 150 \text{ PSF}$$

**Conclusion:**

Non-composite LL = 72.4 PSF

Composite LL = 150 PSF

# Composite Analysis Procedure

(Case 2 – PNA within W-section)

**Given:** Slab and beam geometry  
W-section size and steel grade  
(floor loads)

**Find:** pass/fail or capacities

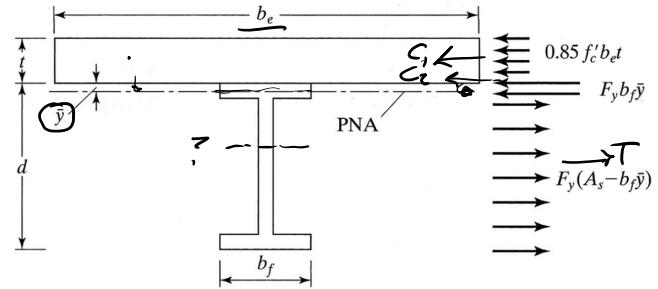

1. Determine effective flange width,  $b_e$
2. Calculate the effective depth of the concrete stress block,  $a$ .
3. If  $a$  is within steel section, the part below the Plastic Neutral Axis (PNA) is in tension and everything above the PNA is in compression (the steel and the concrete)
4. Check if PNA falls within flange or web of the W-section
5. Find  $\bar{y}$  by equating  $T = C$
6.  $M_n = M_p = C_1(z_1) + C_2(z_2) + T(z_3)$
7.  $M_u = \phi M_n$

# Composite Analysis Example

(Case 2 – PNA within W-section)

**Given:** Slab and beam geometry  
W-section size and steel grade  
(floor loads)

**Find:** moment capacity

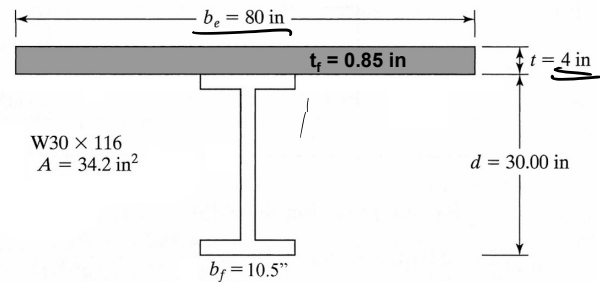

1. Determine effective flange width,  $b_e$  ✓
2. Calculate the effective depth of the concrete stress block,  $a$ .
3. Check if PNA is within upper flange. Assume PNA is at top of web. Check C and T. If C is greater than T, then PNA is within the top flange.

$$a = \frac{A_s f_y}{0.85 f'_c b_e} = \frac{34.2 \text{ in}^2 (50 \text{ ksi})}{0.85 (4 \text{ ksi}) (80)} = 6.29''$$

$6.29'' > 4'' \therefore$  BELOW SLAB

$$C_1 = 0.85 f'_c b_e t = 0.85 (4 \text{ ksi}) (80'') (4'') = 1088 \text{ K}$$

$$C_2 = F_y b_f t_f = 50 \text{ ksi} (10.5'') (0.85'') = 446.25 \text{ K}$$

$$C = C_1 + C_2 = 1088 \text{ K} + 446.25 \text{ K} = 1534 \text{ K}$$

$$T = F_y (A_s - b_f t_f) = 50 (34.2 - 8.925) = 1263.7 \text{ K}$$

$$\sum F_u = 0 = T - C \therefore T = C$$

Since horizontal forces should sum to zero, T should equal C. So C should be less than 1534 and T greater than 1263. Therefore, the PNA must be higher and within the flange.

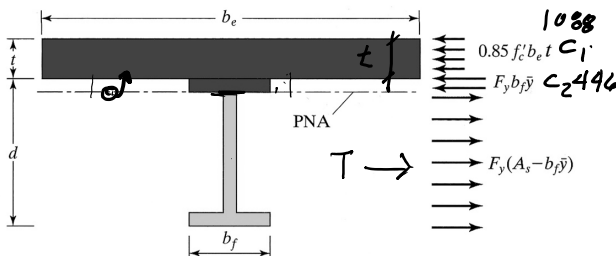

# Composite Analysis Procedure

(Case 2 – PNA within W-section)

- If a is within steel section, only the part below the PNA is in tension and the top is in compression with all concrete
- Check if PNA falls within flange or web of the W-section
- Find  $\bar{y}$  by equating  $T = C$

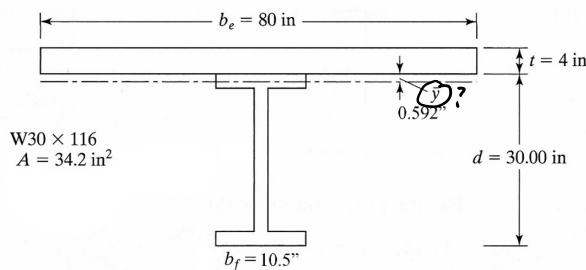
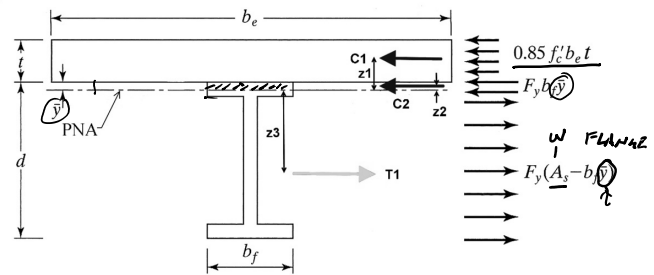

$$\begin{aligned} T &= C \\ (A_s - b_f \bar{y}) F_y &= 0.85 f'_c b_e t + b_f \bar{y} F_y \\ A_s F_y - 0.85 f'_c b_e t &= 2 (b_f \bar{y} F_y) \\ \bar{y} &= \frac{A_s F_y - 0.85 f'_c b_e t}{2 b_f F_y} \end{aligned}$$

# Composite Analysis Procedure

(Case 2 – PNA within W-section)

- Find  $\bar{y}$  by equating  $T = C$
- $M_n = M_p = C_1(z_1) + C_2(z_2) + T(z)$
- $M_u = \phi M_n$

$$\begin{aligned} \bar{y} &= \frac{34.2 \text{ in}^2 (50 \text{ ksi}) - 0.85 (4 \text{ ksi}) (80 \text{ in}) (4 \text{ in})}{2 (10.5 \text{ in}) (50 \text{ ksi})} \\ \bar{y} &= 0.592 \text{ in} \quad t_f = 0.85 \text{ in for W30x116} \end{aligned}$$

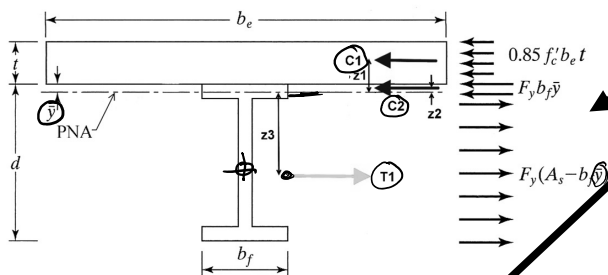

$$\begin{aligned} \sum M_{@PNA} &= C_1(z_1) + C_2(z_2) + T_1(z_3) \\ &= C_1(z_1) + C_2(z_2) + T_1(z_3) \\ M_n = M_p &= 0.85 f'_c b_e t \left( \frac{t}{2} + \bar{y} \right) + 2 F_y b_f \bar{y} \left( \frac{d}{2} \right) + F_y A_s \left( \frac{d}{2} - \bar{y} \right) \end{aligned}$$

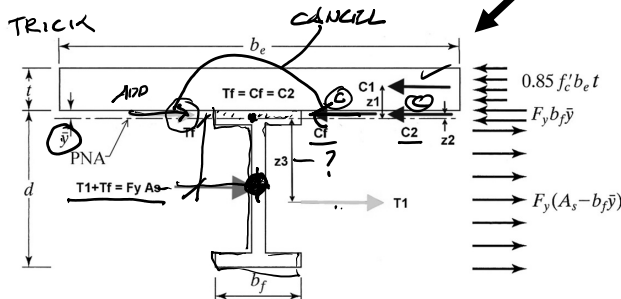

$$\begin{aligned} M_n &= 0.85 (4 \text{ ksi}) (80 \text{ in}) (4 \text{ in}) \left( \frac{4 \text{ in}}{2} + 0.592 \text{ in} \right) \\ &+ 2 (50 \text{ ksi}) (10.5 \text{ in}) (0.592 \text{ in}) \left( \frac{30 \text{ in}}{2} \right) \\ &+ (50 \text{ ksi}) (34.2 \text{ in}^2) \left( \frac{30 \text{ in}}{2} - 0.592 \text{ in} \right) = 27650 \text{ in-k} \\ M_n &= 2304 \text{ ft-k} \end{aligned}$$

MOMENT CAPACITY:

$$M_u = \phi M_n = 0.9 (2304 \text{ ft-k}) = 2074 \text{ ft-k}$$