

Properties of Steel

- Steel Properties
- Steel Profiles
- Steel Codes: ASD vs. LRFD



Current AISC Manual

Specification and Manual for both
ASD and LRFD

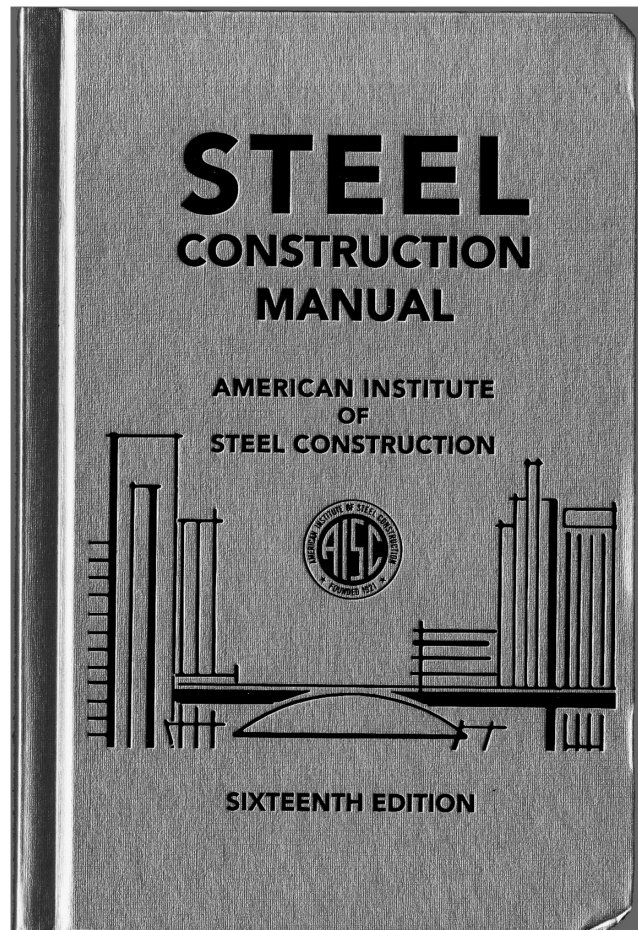

Cold Form Sections



Photos by Albion Sections Ltd, West Bromwich, UK

Cold Form Sections

From:

Building Design Using Cold Formed Steel
 Sections: Structural Design to BS 5950-5:1998.
 Section Properties and Load Tables. p. 276

C sections

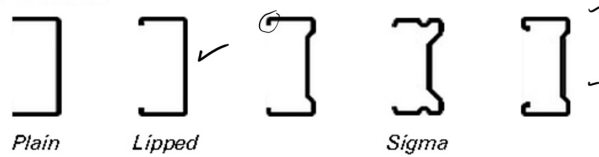

Special sections

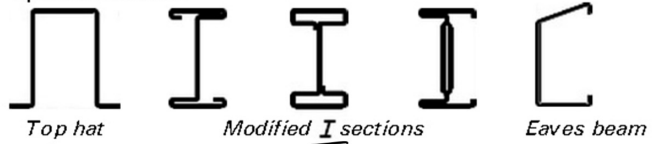

Compound sections

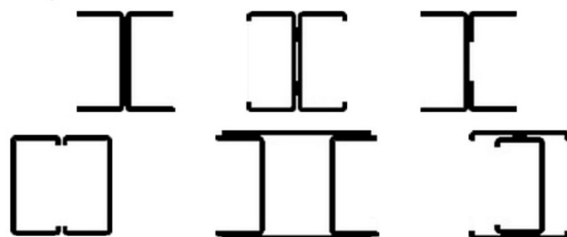
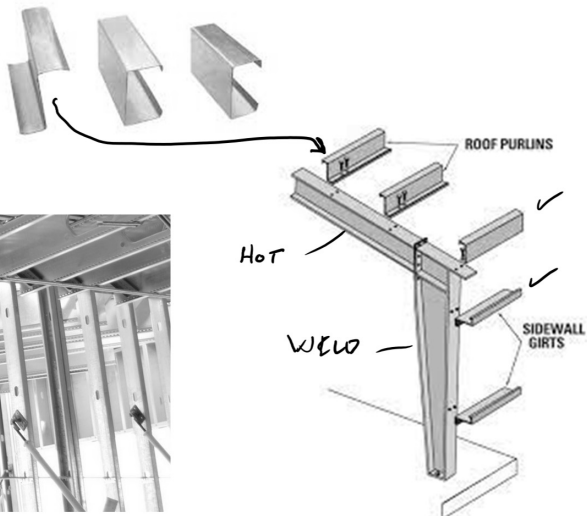
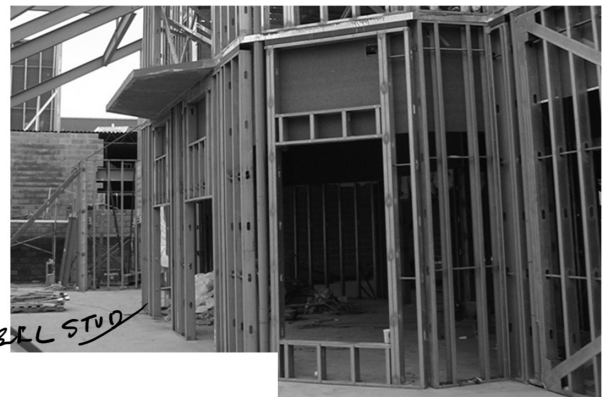
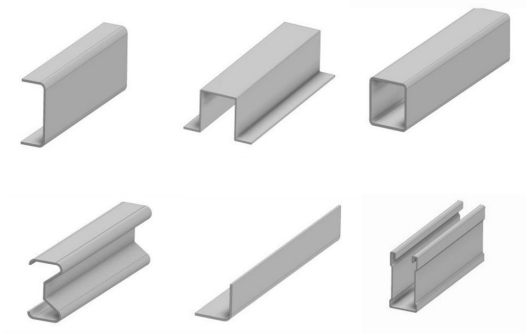

Figure 2.3 Examples of cold formed steel sections

Cold Form Sections



Cold Form Sections



Hot Rolled Shapes

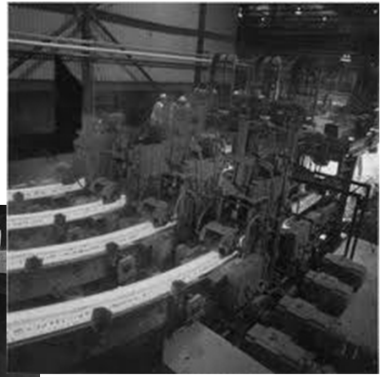

Hot Rolled Shapes

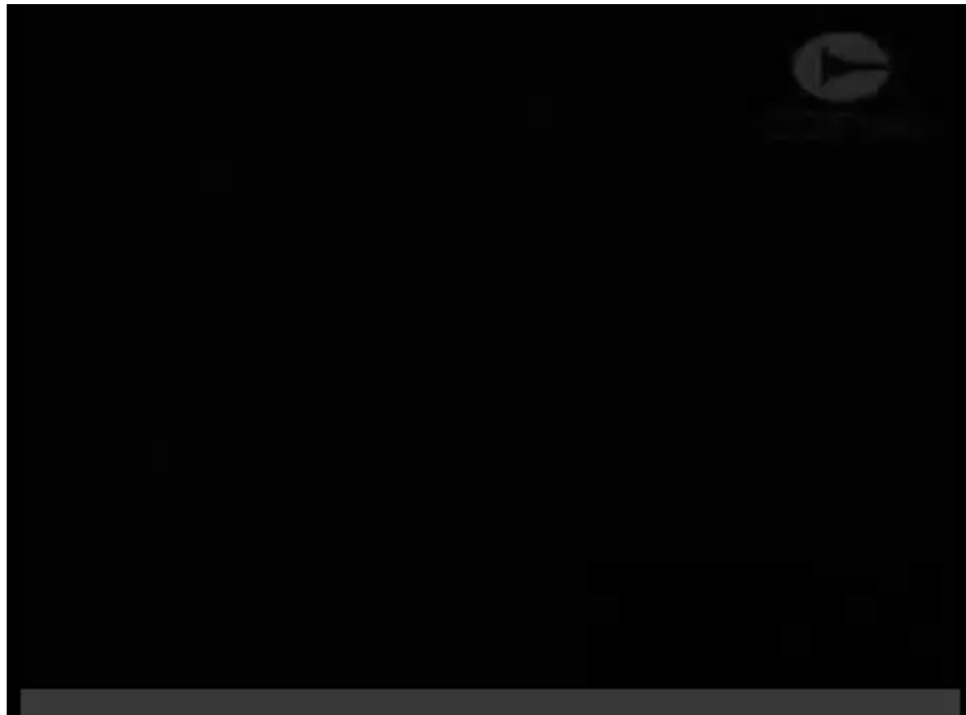

Nomenclature of steel shapes

Standard section shapes:

- W** – wide flange *WF*
- S** – American standard beam
- C** – American standard channel *C*
- L** – angle
- WT** or **ST** – structural T
- STD**, **XS** or **XXS** – Pipe
- HSS** – Hollow Structural Sections
Rectangular, Square, Round
- LLBB**, **SLBB** - Double Angles

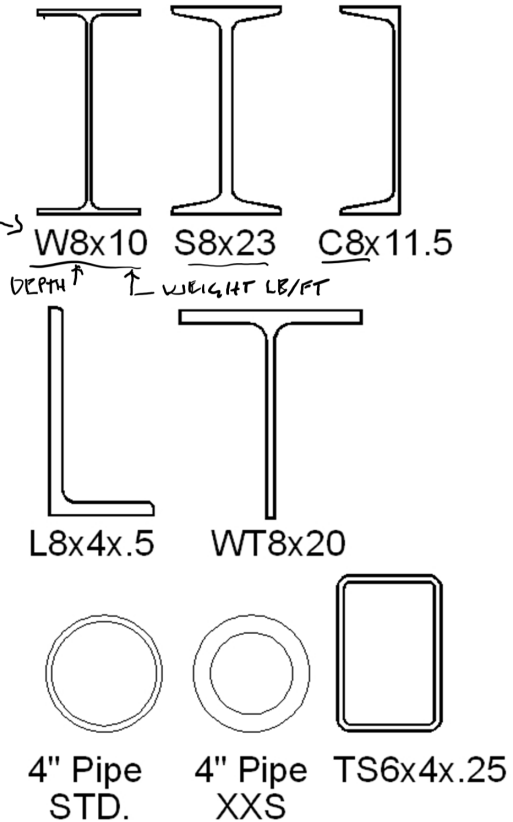

Steel Grades – Rolled Sections

Different sections are made with different grades of steel.

Most structural shapes are:
Gr. 50 Steel with $F_y = 50$ ksi

Older sections were made with:
A-36 Steel with $F_y = 36$ ksi

**Table 2-4
Applicable ASTM Specifications
for Various Structural Shapes**

Steel Type	ASTM Designation	F_y Yield Stress ^(a) ksi	F_u Tensile Stress ^(a) ksi	Applicable Shape Series													
				W	M	S	HP	C	MC	L	Rectangular	Round	HSS Pipe				
Carbon	A36/A36M	36	58-80 ^(b)	■	■	■	■	■	■	■	■	■	■	■	■	■	
	A53/A53M Gr. B	35	60													■	
	A500/ A500M	Gr. B	46	58													■
		Gr. C	50	62													■
	A501/ A501M ^(c)	Gr. D	36	58													■
		Gr. B	46	65													■
	A529/ A529M ^(d)	Gr. 50	50	65-100	■	■	■	■	■	■	■	■	■	■	■	■	
	A529M ^(d)	Gr. 55	55	70-100	■	■	■	■	■	■	■	■	■	■	■	■	■
	A709/A709M	Gr. 36	36	58-80 ^(b)	■	■	■	■	■	■	■	■	■	■	■	■	■
	A1043/ A1043M ^{(e),(f)}	Gr. 36	36-52	58	■	■	■	■	■	■	■	■	■	■	■	■	■
Gr. 50		50-65	65	■	■	■	■	■	■	■	■	■	■	■	■	■	
A1085/ A1085M	Gr. A	50-70	65													■	
High-Strength Low-Alloy	A572/ A572M ^(g)	Gr. 42	42	60												■	
		Gr. 50	50	65	■	■	■	■	■	■	■	■	■	■	■	■	
		Gr. 55	55	70	■	■	■	■	■	■	■	■	■	■	■	■	■
		Gr. 60 ^(h)	60	75	■	■	■	■	■	■	■	■	■	■	■	■	■
		Gr. 65 ^(h)	65	80	■	■	■	■	■	■	■	■	■	■	■	■	■
	A618/ A618M ^(c)	Gr. Ia ⁽ⁱ⁾ , Ib & II	50 ^(j)	70 ^(j)	■	■	■	■	■	■	■	■	■	■	■	■	■
		Gr. III	50	65	■	■	■	■	■	■	■	■	■	■	■	■	■
	A709/ A709M	Gr. 50	50	65	■	■	■	■	■	■	■	■	■	■	■	■	■
		Gr. 50S	50-65	65	■	■	■	■	■	■	■	■	■	■	■	■	■
		Gr. 50W	50	70	■	■	■	■	■	■	■	■	■	■	■	■	■
Gr. 60		60	75	■	■	■	■	■	■	■	■	■	■	■	■	■	
Gr. 65		65	80	■	■	■	■	■	■	■	■	■	■	■	■	■	
A913/ A913M	Gr. 70	70	90	■	■	■	■	■	■	■	■	■	■	■	■	■	
	Gr. 80	80	95	■	■	■	■	■	■	■	■	■	■	■	■	■	
A992/A992M	Gr. 50	50-65	65	■	■	■	■	■	■	■	■	■	■	■	■	■	
A1065/ A1065M ^(l)	Gr. 50	50	60													■	

■ = Preferred material specification
 □ = Other applicable material specification, the availability of which should be confirmed prior to specification
 ◻ = Material specification does not apply

Footnotes on facing page.

Steel W-sections for beams and columns

Columns:

Closer to square
Thicker web & flange

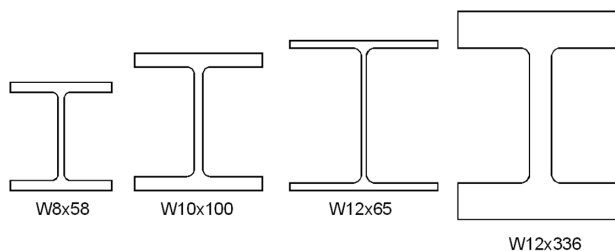

Beams:

Deeper sections
Flange thicker than web

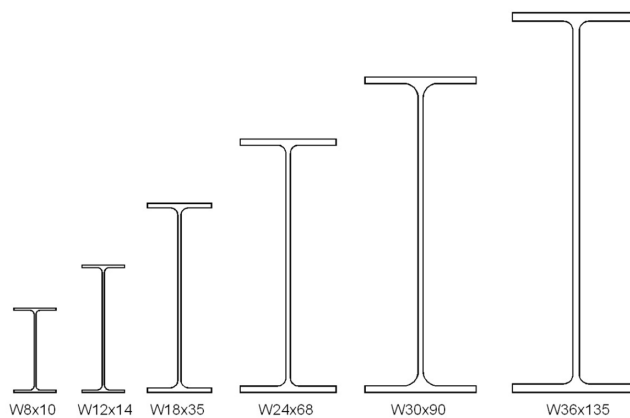

Steel W-sections for beams and columns

Columns:

Closer to square
Thicker web & flange

Beams:

Deeper sections
Flange thicker than web



Photo by Gregor Y.

Modified Sections

- Castellated Sections:
- “Boyd beam”
- round, hexagonal, rectangular, sinusoidal
- extendable (added depth)
- cost-efficient
- lightweight

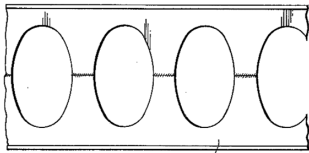
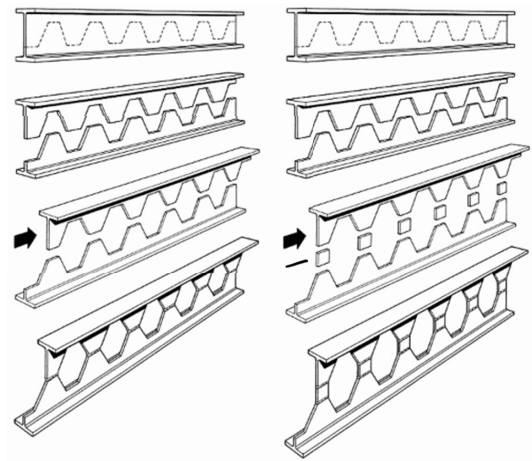
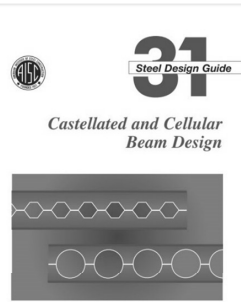

Fig. 2A.

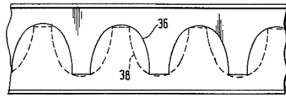

Fig. 2B.



Young's Modulus

Young's Modulus or the Modulus of Elasticity, is obtained by dividing the stress by the strain present in the material. (Thomas Young, 1807)

$$E = \frac{P/A}{D/L} = \frac{\sigma}{\epsilon}$$

It thus represents a measure of the stiffness of the material.

STRESS VS. STRAIN FOR YELLOW POPLAR IN COMPRESSION

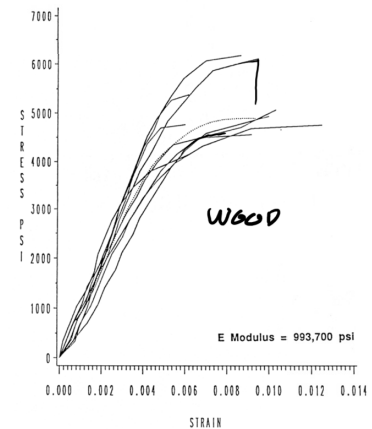

$E = 1000 \text{ ksi}$

Concrete

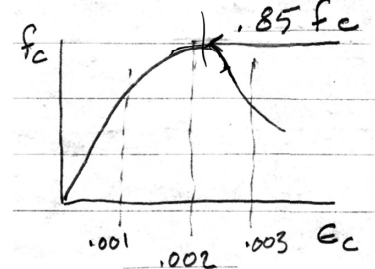

$E = 3500 \text{ ksi}$

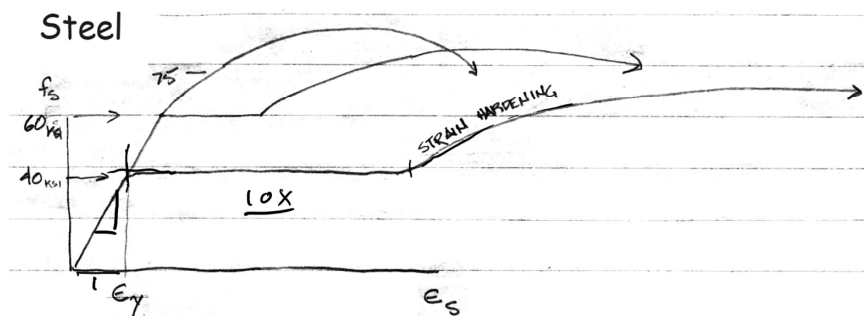

$E = 29000 \text{ ksi}$

Stress vs. Strain – mild steel

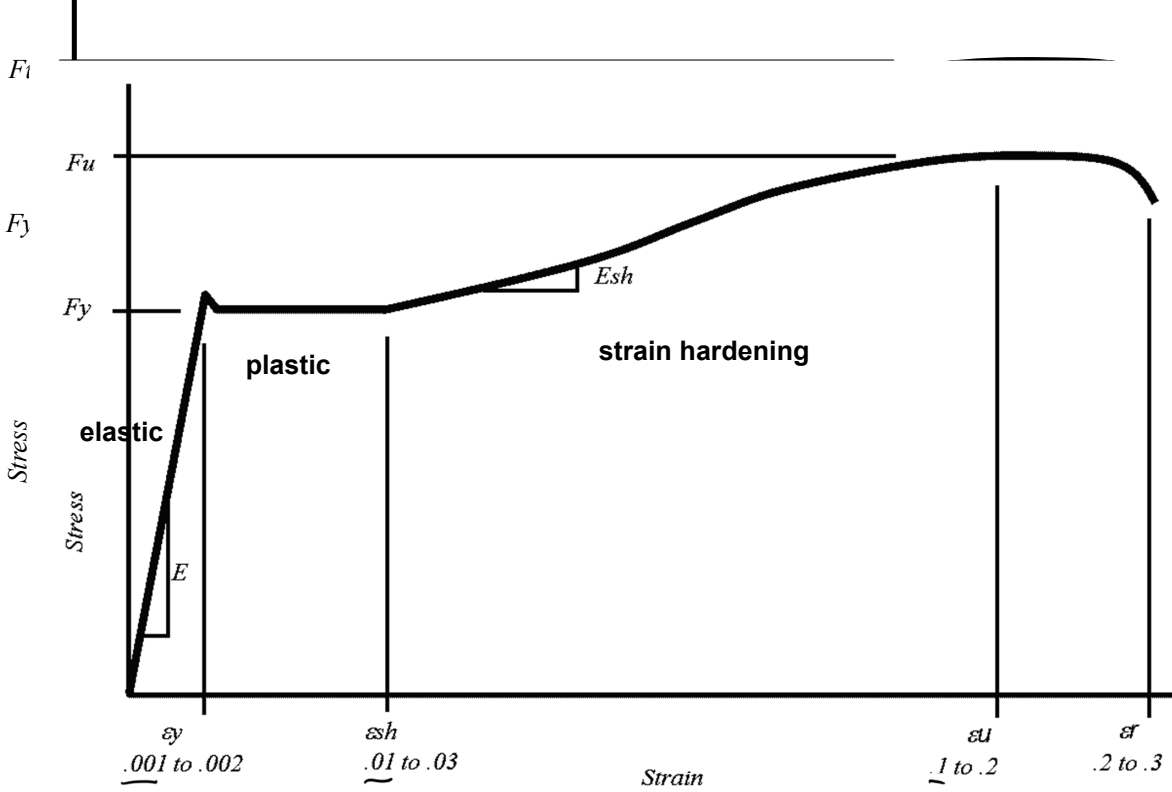

Developed by Scott Civan
University of Massachusetts, Amherst

Stress vs. Strain – AISC design curve

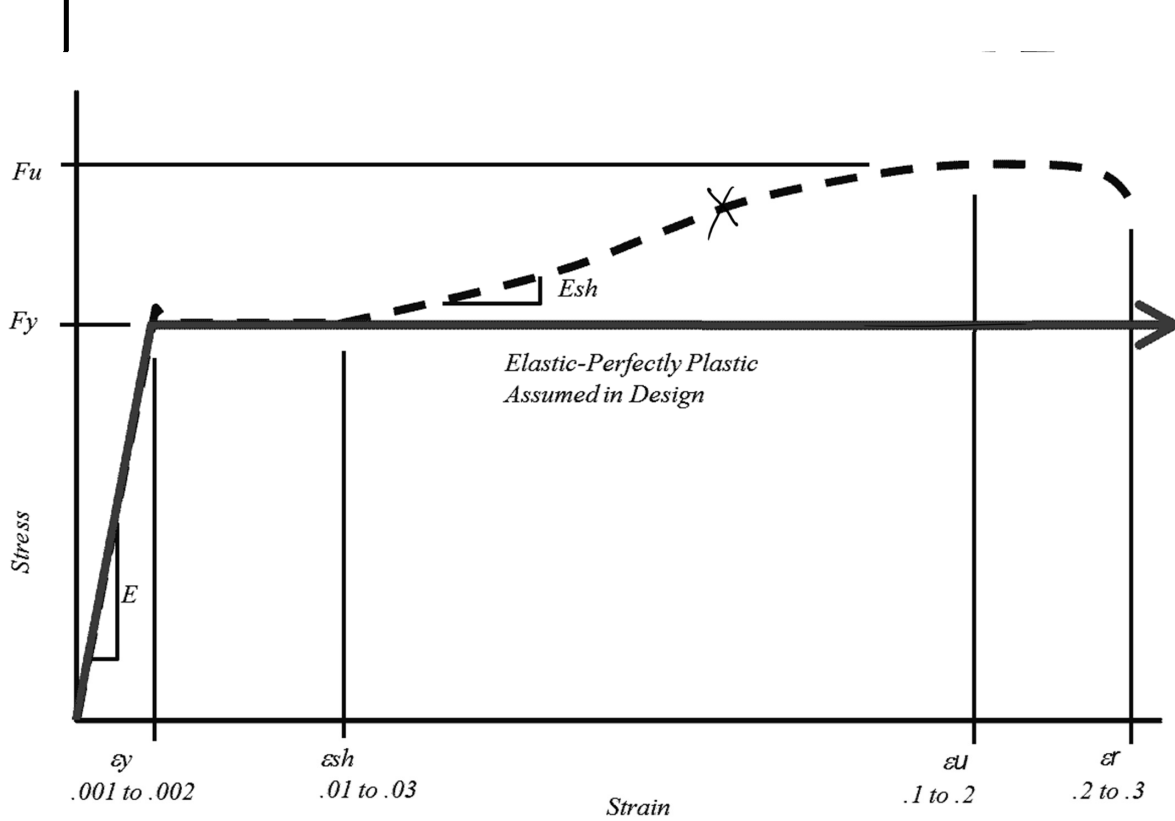

Stress Analysis – Two Methods

Allowable Stress Design (ASD) *WOOD*

- use design loads (no F.S. on loads)
- reduce stress by a Factor of Safety F.S.

$$f_{actual} = \frac{P}{A}$$

$$f_{actual} \leq F_{allowable}$$

$$F_{allowable} = F.S. \cdot f_{yield}$$

Load & Resistance Factored Design (LRFD) *STEEL*

- Use loads with safety factor γ
- Use factor on ultimate strength ϕ

$$P_{load} = \gamma \cdot P_{applied_load}$$

$$P_{load} \leq P_{resisting}$$

$$P_{resisting} = \phi \cdot P_{material_strength}$$

LRFD Analysis

Load & Resistance Factored Design (LRFD)

- Use loads with safety factor γ
- Use forces with strength factor ϕ

$$P_{load} = \gamma \cdot P_{applied}$$

$$P_{load} \leq P_{resisting}$$

$$P_{resisting} = \phi \cdot P_{material}$$

Design Strength

$$P_u \leq \phi P_n$$

Required (Nominal) Strength

2.3 LOAD COMBINATIONS FOR STRENGTH DESIGN

- 1a. $1.4D$
- 2a. $1.2D + 1.6L + (0.5L_r \text{ or } 0.3S \text{ or } 0.5R)$
- 3a. $1.2D + (1.6L_r \text{ or } 1.0S \text{ or } 1.6R) + (L \text{ or } 0.5W)$
- 4a. $1.2D + 1.0(W \text{ or } W_T) + L + (0.5L_r \text{ or } 0.3S \text{ or } 0.5R)$
- 5a. $0.9D + 1.0(W \text{ or } W_T)$

Beam Strength vs Unbraced Length

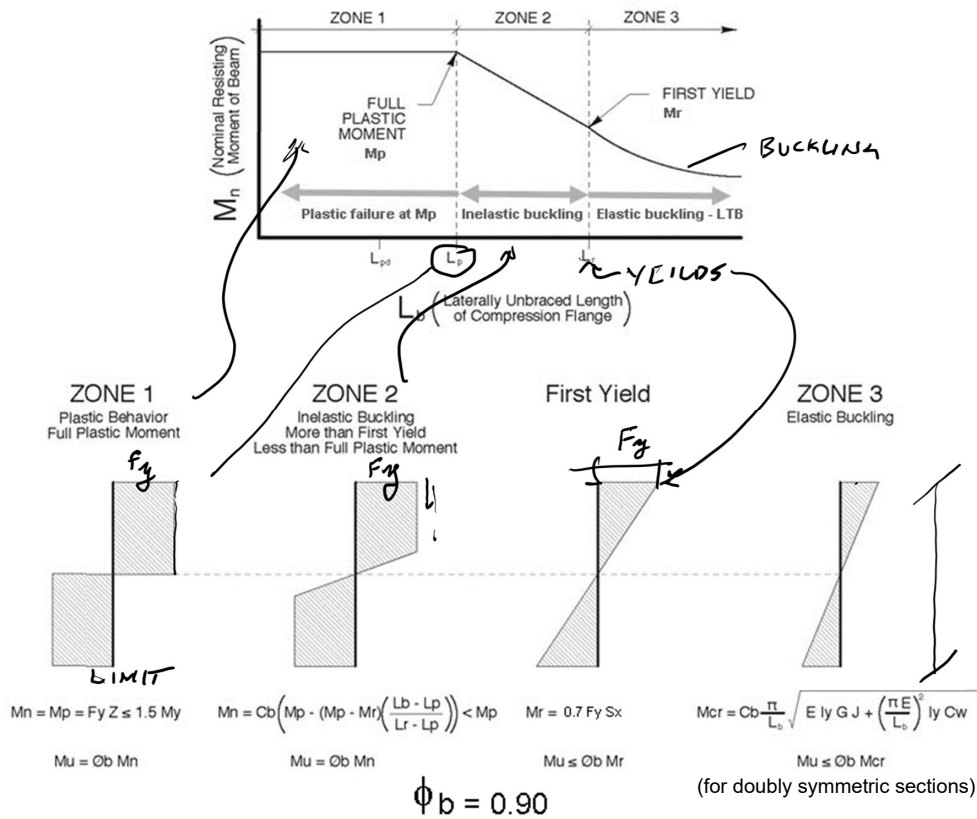

Steel Beams by LRFD

Yield Stress Values

- A36 Carbon Steel $F_y = 36$ ksi
- A992 High Strength $F_y = 50$ ksi

Elastic Analysis for Bending

Plastic Behavior (zone 1)

$$M_n = M_p = F_y Z < 1.5 M_y$$

- Braced against LTB ($L_b < L_p$)

Inelastic Buckling "Decreased" (zone 2)

$$M_n = C_b \left(M_p - (M_p - M_r) \left[\frac{L_b - L_p}{L_r - L_p} \right] \right) < M_p$$

- $L_p < L_b < L_r$

Elastic Buckling "Decreased Further" (zone 3)

$$M_{cr} = C_b \frac{\pi^2}{L_b^2} \sqrt{E I_y G J + (\pi^2 E / L_b)^2 I_y C_w}$$

- $L_b > L_r$

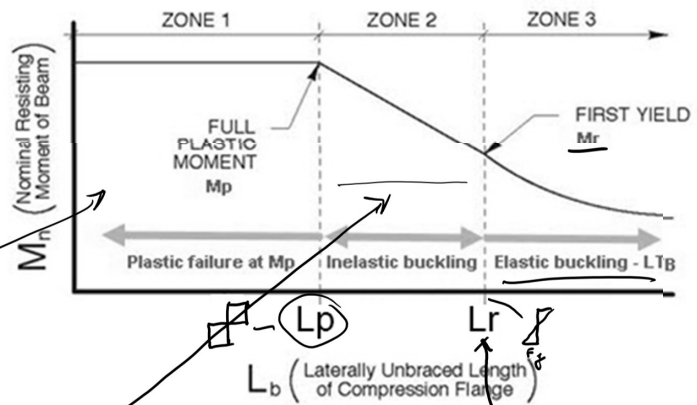

$$L_p = 1.76 r_y \sqrt{E / F_y}$$

$$M_p = F_y (Z_x)$$

$$M_r = 0.7 F_y S_x$$

F.S.

C_b is LTB modification factor

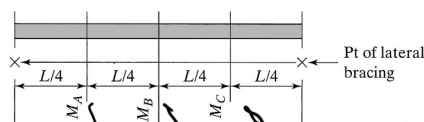

$$C_b = \frac{12.5 M_{max}}{2.5 M_{max} + 3 M_A + 4 M_B + 3 M_C}$$

Steel Beams by LRFD

Analysis for Bending

AISC 16th ed.

- Plastic Behavior (zone 1)

$$M_n = M_p = F_y Z_x < 1.5 M_y$$

- Braced against LTB ($L_b < L_p$)

- Inelastic Buckling "Decreased" (zone 2)

$$M_n = C_b (M_p - (M_p - M_r) [(L_b - L_p) / (L_r - L_p)]) < M_p$$

- $L_p < L_b < L_r$

- Elastic Buckling "Decreased Further" (zone 3)

$$M_{cr} = C_b * \pi / L_b \sqrt{(E * I_y * G * J + (\pi * E / L_b)^2 * I_y C_w)}$$

- $L_b > L_r$

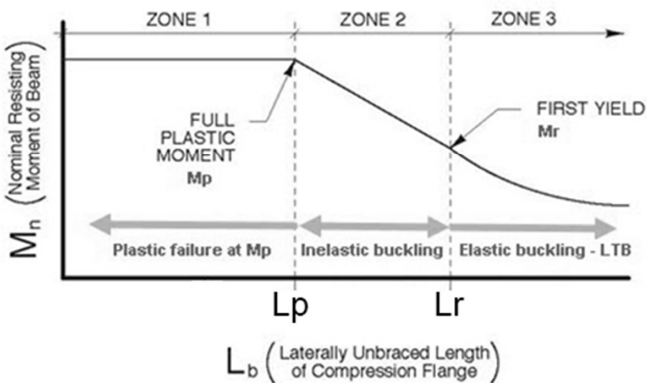

Table 3-2 (continued)
W-Shapes
Selection by Z_x

$F_y = 50$ ksi

ASD LRFD
ASD LRFD

Z_x

Shape	Z_x in. ³	M_n/Ω_b		$\phi_b M_n$		M_n/Ω_b		$\phi_b M_n$		BF/Ω_b ASD	$\phi_b BF$ LRFD	L_p ft	L_r ft	I_x in. ⁴	V_n/Ω_v		$\phi_v V_n$	
		kip-ft	kip-ft	kip-ft	kip-ft	kip-ft	kip-ft	ASD	LRFD									
		ASD	LRFD	ASD	LRFD	ASD	LRFD											
W21x55	126	314	473	192	289	10.8	16.3	6.11	17.4	1140	156	234						
W14x74	126	314	473	186	294	5.31	8.05	8.76	31.0	795	128	192						
W18x60	123	307	461	189	284	9.62	14.4	5.93	18.2	984	151	227						
W12x79	119	297	446	187	281	3.78	5.67	10.8	39.9	662	117	175						
W14x68	115	287	431	180	270	5.19	7.81	8.69	29.3	722	116	174						
W10x88	113	282	424	172	259	2.62	3.94	9.29	51.2	534	131	196						
W18x55	112	279	420	172	258	9.15	13.8	5.90	17.6	890	141	212						
W21x50	110	274	413	165	248	12.1	18.3	4.59	13.6	984	158	237						
W12x72	108	269	405	170	256	3.69	5.56	10.7	37.5	597	106	159						
W21x48 ⁽¹⁾	107	265	398	162	244	9.89	14.8	6.09	16.5	959	144	216						
W16x57	105	262	394	161	242	7.98	12.0	5.65	18.3	758	141	212						
W14x61	102	254	383	161	242	4.93	7.48	8.65	27.5	640	104	156						
W18x50	101	252	379	155	233	8.76	13.2	5.83	16.9	800	128	192						
W10x77	97.6	244	366	150	225	2.60	3.90	9.18	45.3	455	112	169						
W12x65 ⁽¹⁾	96.8	237	356	154	231	3.58	5.39	11.9	35.1	533	94.4	142						
W21x44	95.4	238	358	143	214	11.1	16.8	4.45	13.0	843	145	217						
W16x50	92.0	230	345	141	213	7.69	11.4	5.62	17.2	659	124	186						
W18x46	90.7	226	340	138	207	9.63	14.6	4.56	13.7	712	130	195						
W14x53	87.1	217	327	136	204	5.22	7.93	6.78	22.3	541	103	154						
W12x58	86.4	216	324	136	205	3.82	5.69	8.87	29.8	475	87.8	132						
W10x68	85.3	213	320	132	199	2.58	3.85	9.15	40.6	394	97.8	147						
W16x45	82.3	205	309	127	191	7.12	10.8	5.55	16.5	586	111	167						
W18x40	78.4	196	294	119	180	8.94	13.2	4.49	13.1	612	113	169						
W14x48	78.4	196	294	123	184	5.09	7.67	6.75	21.1	484	93.8	141						
W12x53	77.9	194	292	123	185	3.65	5.50	7.82	28.2	425	83.5	125						
W10x60	74.6	186	280	116	175	2.54	3.82	9.08	36.6	341	85.7	129						
W16x40	73.0	182	274	113	170	6.67	10.0	5.55	15.9	518	97.6	146						
W12x50	71.9	179	270	112	169	3.97	5.98	6.92	23.8	391	90.3	135						
W8x67	70.1	175	263	106	159	1.75	2.59	7.49	47.6	272	70.3	104						
W14x43	69.6	174	261	109	164	4.88	7.28	6.68	20.0	428	83.6	125						
W10x54	66.6	166	250	105	158	2.48	3.75	9.04	33.6	303	74.7	112						

F.S.

ASD LRFD

⁽¹⁾Shape exceeds compact limit for flexure with $F_y = 50$ ksi; tabulated values have been adjusted accordingly.

$\Omega_b = 1.67$ $\phi_b = 0.90$
 $\Omega_v = 1.50$ $\phi_v = 1.00$

Design for Shear

Steel

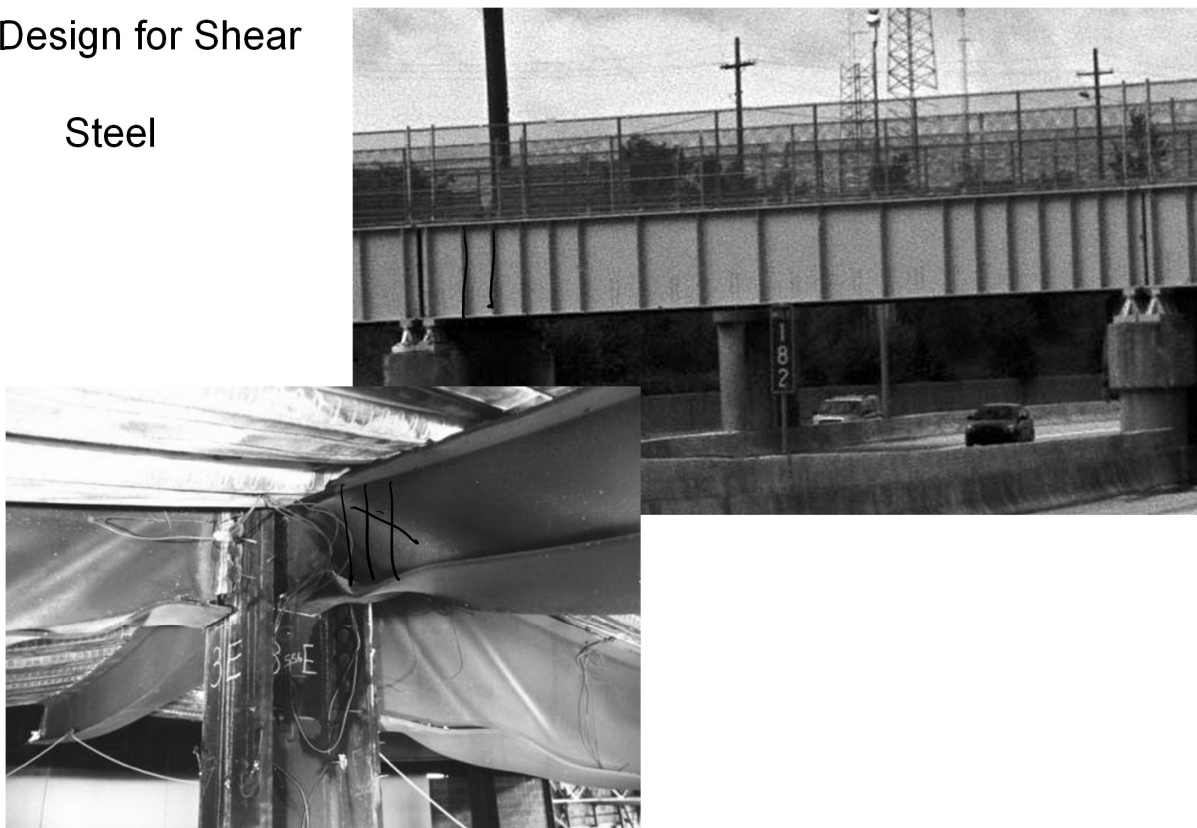

Design for Shear

Shear stress in steel sections is approximated by averaging the stress in the web:

$$F_v = \frac{V}{A_w}$$

$$A_w = d * t_w$$

To adjust the stress a reduction factor of 0.6 is applied to F_y

$$F_v = 0.6 F_y$$

so, $V_n = 0.6 F_y A_w$ (Zone 1)

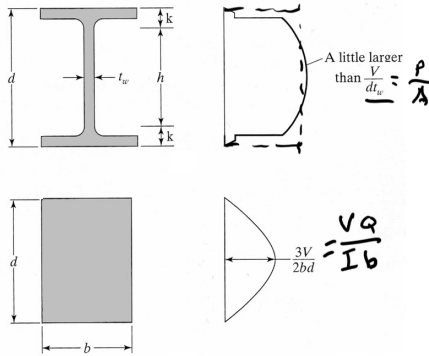

The equations for the 3 stress zones:
(ϕ in all cases = 1.0)

Zone 1:

WEB YIELDING (Most beam sections fall into this category)

if $\frac{h}{t_w} \leq 2.45 \sqrt{E/F_y} = 59$ (for 50 ksi steel)

then: $V_n = 0.6 F_y A_w$

Zone 2:

INELASTIC WEB BUCKLING

if $2.45 \sqrt{E/F_y} < \frac{h}{t_w} \leq 3.07 \sqrt{E/F_y} = 74$ (for 50 ksi steel)

then: $V_n = 0.6 F_y A_w (2.45 \sqrt{E/F_y}) / \frac{h}{t_w}$

Zone 3:

ELASTIC WEB BUCKLING

if $3.07 \sqrt{E/F_y} < \frac{h}{t_w} \leq 260$

then: $V_n = A_w \left[\frac{4.25 E}{\left(\frac{h}{t_w}\right)^2} \right]$

Design for Shear

No W, M, S or HP section has $h/t_w > 59$

Zone 1:

WEB YIELDING (Most beam sections fall into this category)

if $\frac{h}{t_w} \leq 2.45 \sqrt{E/F_y} = 59$ (for 50 ksi steel)

then: $V_n = 0.6 F_y A_w$

Zone 2:

INELASTIC WEB BUCKLING

if $2.45 \sqrt{E/F_y} < \frac{h}{t_w} \leq 3.07 \sqrt{E/F_y} = 74$ (for 50 ksi steel)

then: $V_n = 0.6 F_y A_w (2.45 \sqrt{E/F_y}) / \frac{h}{t_w}$

Zone 3:

ELASTIC WEB BUCKLING

if $3.07 \sqrt{E/F_y} < \frac{h}{t_w} \leq 260$

then: $V_n = A_w \left[\frac{4.25 E}{\left(\frac{h}{t_w}\right)^2} \right]$

W-Shapes Properties



W30-W27

Nominal Wt. lb/ft	Compact Section Criteria		Axis X-X					Axis Y-Y				r_{ts}	h_o	Torsional Properties	
	$b_t/2t_f$	h/t_w	I	S	r	Z	I	S	r	Z	J			C_w	
	in.	in.	in. ⁴	in. ³	in.	in. ³	in. ⁴	in. ³	in.	in. ³	in.	in.	in. ⁴	in. ⁶	
391	3.19	19.7	20700	1250	13.4	1450	1550	198	3.67	310	4.37	30.8	173	366000	
357	3.45	21.6	18700	1140	13.3	1320	1390	179	3.64	279	4.31	30.6	134	324000	
326	3.75	23.4	16800	1040	13.2	1190	1240	162	3.60	252	4.26	30.4	103	287000	
292	4.12	26.2	14900	930	13.2	1060	1100	144	3.58	223	4.22	30.2	75.2	250000	
261	4.59	28.7	13100	829	13.1	943	959	127	3.53	196	4.16	30.0	54.1	215000	
235	5.02	32.2	11700	748	13.0	847	855	114	3.51	175	4.13	29.8	40.3	190000	
211	5.74	34.5	10300	665	12.9	751	757	100	3.49	155	4.11	29.6	28.4	166000	
191	6.35	37.7	9200	600	12.8	675	673	89.5	3.46	138	4.06	29.5	21.0	146000	
173	7.04	40.8	8230	541	12.7	607	598	79.8	3.42	123	4.03	29.3	15.6	129000	