

Arch324

STRUCTURES II

Winter 2026
Recitation

FACULTY: Prof. Peter von Bülow
Mohsen Vatandoost

Arch324: STRUCTURES II

Welcome to Recitation session 04/10

Mohsen Vatandoost {Ph.D., M.Sc., M. Arch}

mohsenv@umich.edu

Office: Room 3128

hours:

Fri: 11:30 – 12:30

Mon, Wed: 11:00 - 12:00

walk-ins welcome!

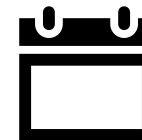

[Click here to make an appointment](#)

Please feel free to ask questions.

Arch324: STRUCTURES II

Welcome to the Recitation session 04/10

Outline:

- Quick **Recap** of the week
- Provide the solution for the assignment (**Homework 10**)
- Answering students' questions
- Lab: **Composite Section**
- **Tower Project:** Final report by **April 17**
- **Course Evaluation** (20+ bonus points)

Please feel free to ask questions.

Tower Project:

Tower Project final report:

April, 17

PRELIMINARY REPORT (re-submit with final report)	40	
TESTING	60	
Tower weight \leq 4oz (15 pts); height = 48" (5 pts); holds \geq 50 lbs (5 pts) Correct Materials (5 pts) (scaled if doesn't meet requirements)	30	
Efficiency $(4/\text{weight OZ})+(\text{load LBS}/50)+(\text{load LBS}/\text{weight OZ})\times 1.5$ (scaled based on class rank)	30	
FINAL REPORT REQUIREMENTS	150	

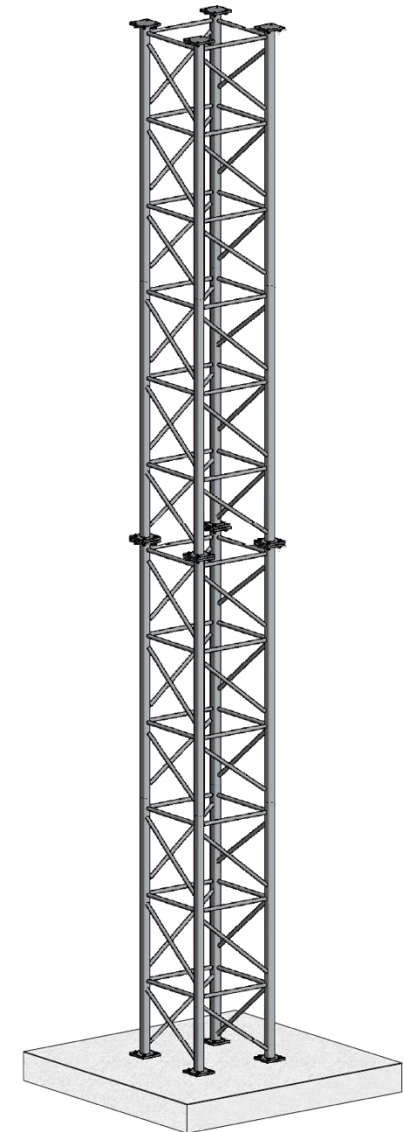

Recap of the week

Analysis Procedure (LRFD)

Case 1 – Plastic Neutral Axis (PNA) within slab

Case 2 – PNA within steel section

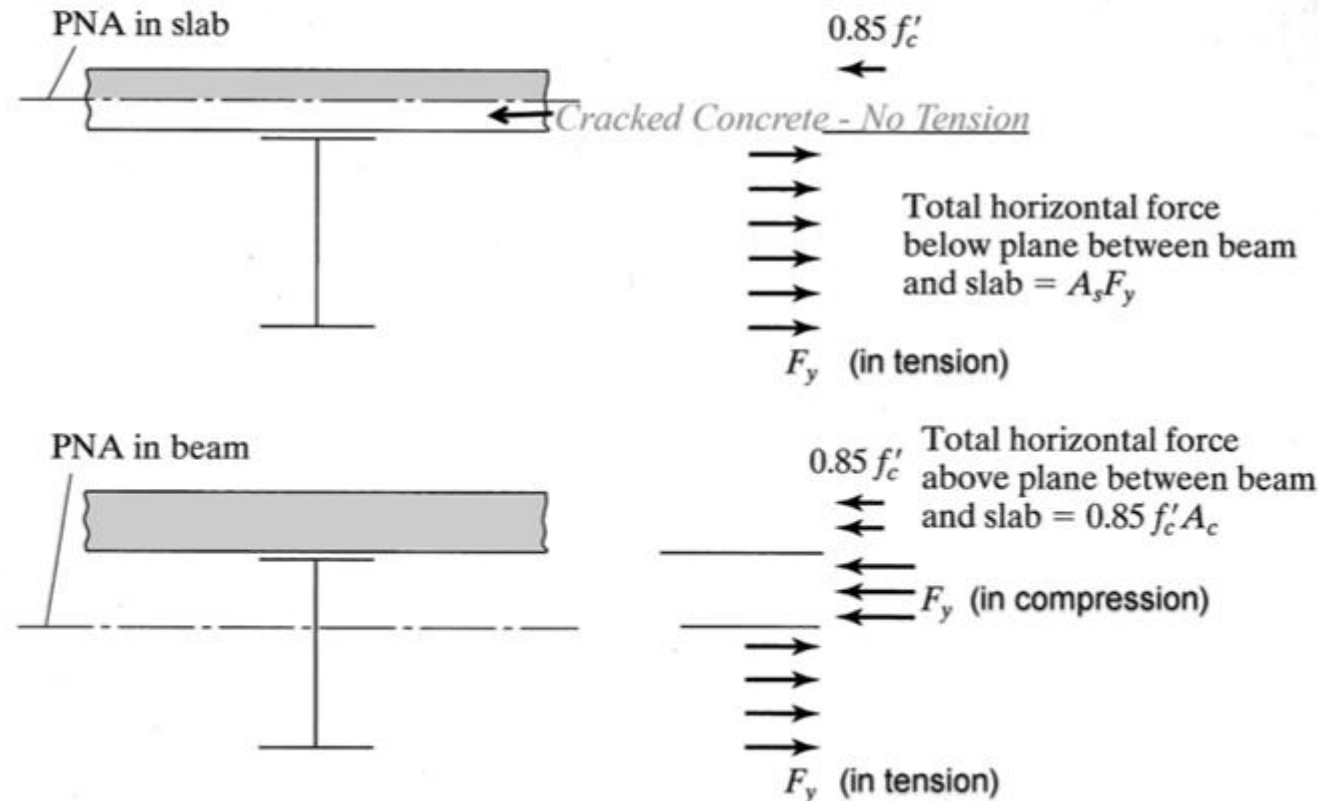

Recap of the week

Analysis Procedure (LRFD)

Case1 – PNA within slab

Given: Slab and beam geometry
W-section size and steel grade
(floor loads)

Find: pass/fail or capacities

1. Define effective flange width, b_e
2. Calculate the effective depth of the concrete stress block, a
3. If a is within concrete slab, the full steel section is in tension and:
 $M_p = T z$
 $M_n = M_p = A_s F_y (d/2 + t - a/2)$
4. $M_u \leq \phi M_n$

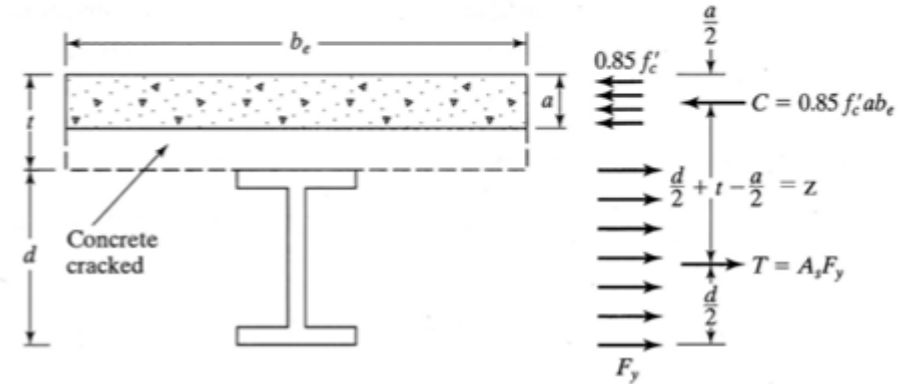

$$T = C$$

$$A_s f_y = 0.85 f'_c a b_e$$

$$a = \frac{A_s f_y}{0.85 f'_c b_e}$$

Provide the solution for the assignment – HW10

10. Composite Sections

Using the strength method, determine the required amount of flexural steel reinforcement, A_s , for the simple span beam (shown in section). The beam carries a dead and live floor load from a one-way slab in addition to its own self weight at 150 PCF. For the given bar size, determine the number of bars to obtain the required A_s . Check $A_{s,min}$ and ϵ_{t} . Calculate the strength moment, M_n for the final beam design and check that ϕM_n is $> M_u$.

DATASET: 1

-2-

-3-

W-section	W21X166
span A	70 FT
span B	18 FT
slab thickness, t	9 IN
steel yield stress, F_y	50 KSI
concrete ultimate stress, f'_c	5 KSI

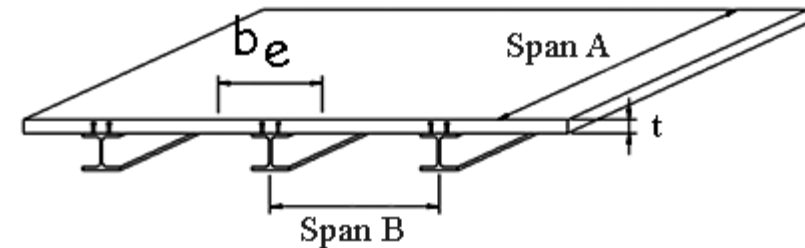

Provide the solution for the assignment – HW10

#	Question	Your Response
1	Effective width of the concrete flange, b_e	<input type="text"/> IN
2	Depth of concrete stress block, a	<input type="text"/> IN
3	Is depth a within the slab? 1=yes, 0=no	<input type="text"/>
4	The nominal bending moment, M_n	<input type="text"/> K-IN
5	The factored bending resistance, ϕM_n	<input type="text"/> K-IN
6	The factored design moment, M_u	<input type="text"/> K-FT
7	The total factored design load, w_u	<input type="text"/> KLF
8	The selfweight of the concrete slab	<input type="text"/> PSF
9	The total (steel+concrete) unfactored dead load on the beam, w_{DL}	<input type="text"/> KLF
10	The actual, unfactored beam live load (capacity), w_{LL}	<input type="text"/> KLF
11	The actual floor live load (floor capacity), LL	<input type="text"/> PSF

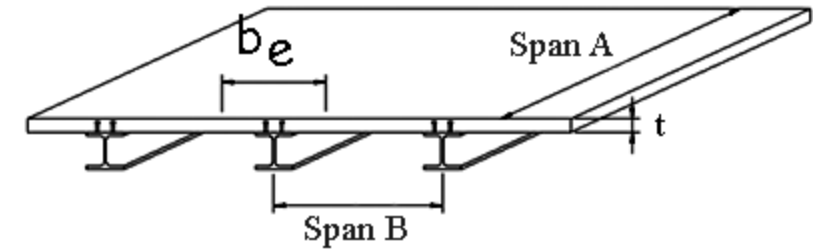

Provide the solution for the assignment – HW10

①

effective width

Min

Q1

$$\frac{1}{4} (\text{span of steel beam})$$

$$\frac{1}{4} (70 \times 12) = 210''$$

$$b_f + 2(8 \times \text{slab thickness})$$

$$12.4 + 2(8 \times 9) = 156.4''$$

$$b_f + 2\left(\frac{1}{2} \text{ clear distance}\right)$$

$$18 \times 12 = 216''$$

W21 X166

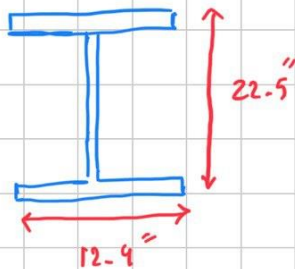

$$A = 48.8 \text{ in}^2$$

$$w = 166 \frac{\text{lb}}{\text{ft}} \text{ (PLF)}$$

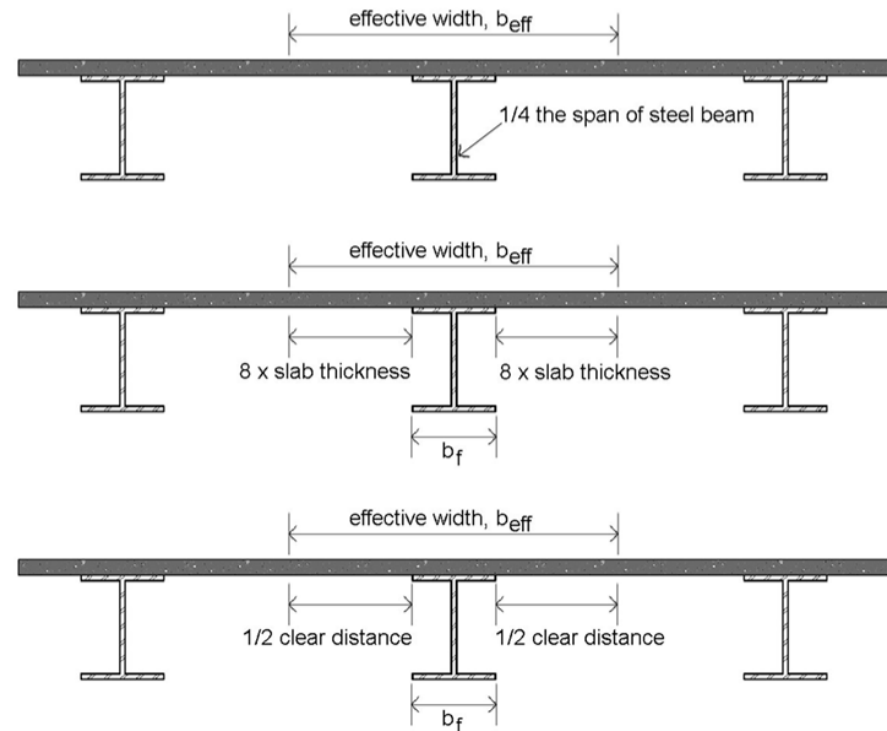

Provide the solution for the assignment – HW10

② effective depth of concrete stress block, a

$$a = \frac{A_s F_y}{0.85 F'_c b_e} = \frac{(48.8) (50)}{0.85 (5) (156.4)} = 3.6708'' < 9''$$

within slab

Q2

Q3

④ If a is within conc. slab, the full steel section is in tension:
nominal bending moment:

$$M_n = M_p = A_s F_y \left(\frac{d}{2} + t - \frac{a}{2} \right)$$

slab thickness (pointing to t)
concrete stress block (pointing to a)

$$= (48.8) (50) \left(\frac{22.5}{2} + 9 - \frac{3.6708}{2} \right) = 44931.62 \text{ K-in}$$

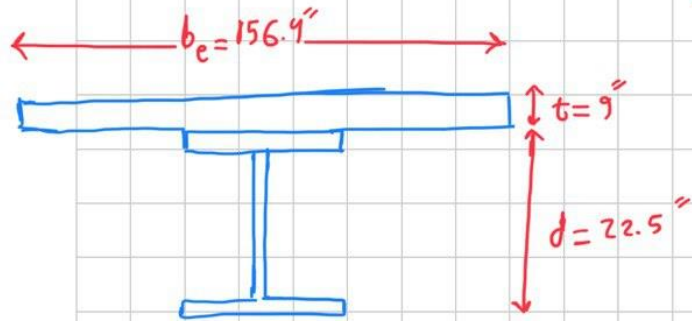

Provide the solution for the assignment – HW10

⑤ $\phi M_n = 0.9 (44931.62) = 40438.45 \text{ k-in}$

Q5

⑥ $M_u \leq \phi M_n \rightarrow M_u = \phi M_n$
 $40438.45 \times \frac{1}{12} = 3369.87 \text{ k-ft}$

Q6

⑦ $M_u = \frac{w_u L^2}{8} \rightarrow w_u = \frac{8 M_u}{L^2} = \frac{8 (3369.87 \text{ k-ft})}{(70)^2} = 5.5018 \text{ kLF}$
(L² is circled in red with an arrow pointing to "Span A")

Q7

⑧ Self-weight of concrete slab:

$\frac{9}{12} \text{ ft}^3 \times 150 = 112.5 \text{ pSF}$

Q8

Provide the solution for the assignment – HW10

⑨ Total unfactored dead load:

Self weight (Concrete + steel)

$$\begin{aligned} 18(112.5) + 166 &= 2191 \text{ pLF} \\ &= 2.191 \text{ KLF} \end{aligned}$$

Tributary area width

Q9

⑩ Actual unfactored live load, w_{LL}

$$w_u = 1.2 w_{DL} + 1.6 w_{LL}$$

$$5.5018 \text{ KLF} = 1.2(2.191) + 1.6(w_{LL}) \rightarrow w_{LL} = 1.7953 \text{ KLF}$$

Q10

⑪ Actual floor live load:

$$\frac{w_{LL}}{\text{Span}} = \frac{1.7953 \text{ KLF}}{18} = 0.0997388 \text{ KSF} \times 1000 = 99.7388 \text{ PSF}$$

Q11

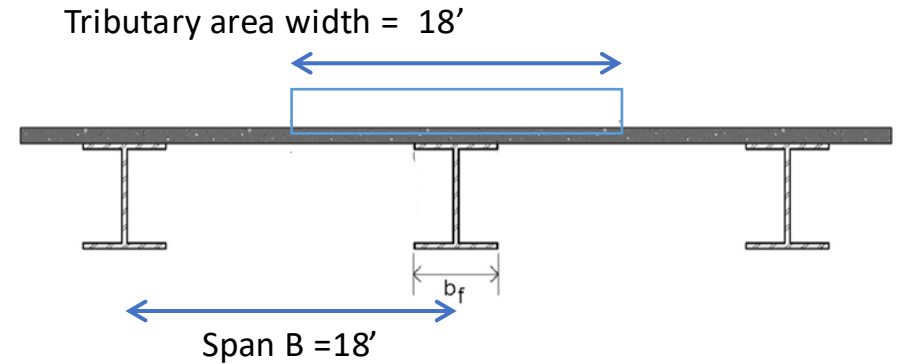

Lab : Composite Sections

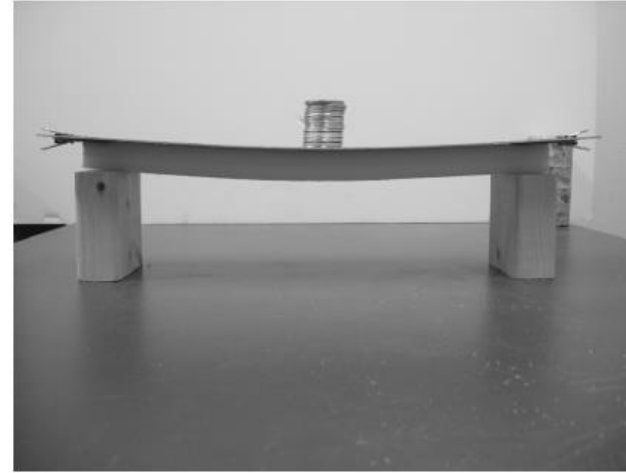
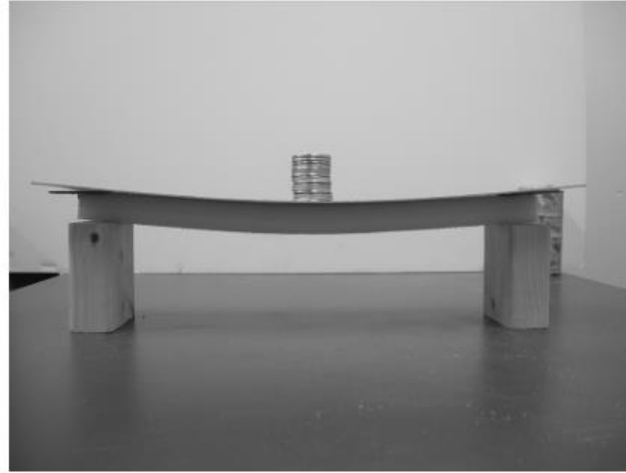

Description

This project allows the students to observe the difference in stiffness between Composite and Non-Composite beam slab combinations.

Goals

- To observe the bending behavior of non-connected beams and slabs
- To observe the bending behavior of a composite section.
- To compare the deflection of the two systems.

Lab : Composite Sections

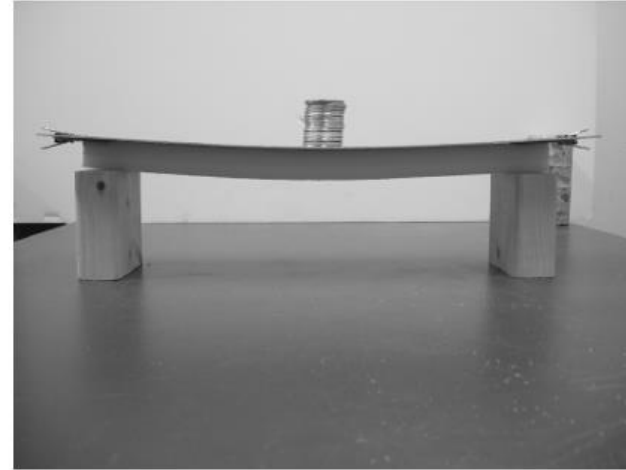
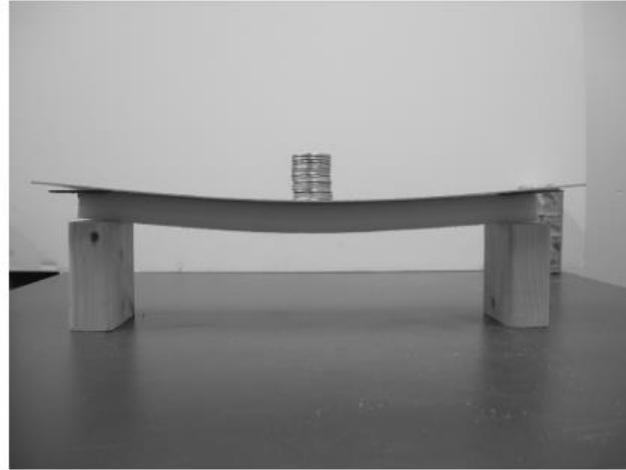

Procedure

1. Place the chipboard slab on the foam beam but do not attach the end clips.
2. Place the 10 washer weights in the center and measure the deflection.
3. Repeat the procedure but now with the ends of the slab and the beam clipped together.
4. Again, measure the deflection.
5. Compare the deflections of the two systems.

Arch324: STRUCTURES II

Thank you.

Any question?

Please feel free to ask questions.