

Arch324

STRUCTURES II

Spring 2026
Recitation

FACULTY: Prof. Peter von Bülow
Mohsen Vatandoost

Arch324: STRUCTURES II

Welcome to Recitation session 03/20

Mohsen Vatandoost {Ph.D., M.Sc., M. Arch}

mohsenv@umich.edu

Office: Room 3128

hours:

Fri: 11:30 – 12:30

Mon, Wed: 11:00 - 12:00

walk-ins welcome!

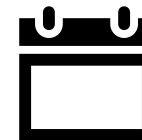

[Click here to make an appointment](#)

Please feel free to ask questions.

Tower Project:

Tower Test : **March 30th**

Please sign up and schedule time.

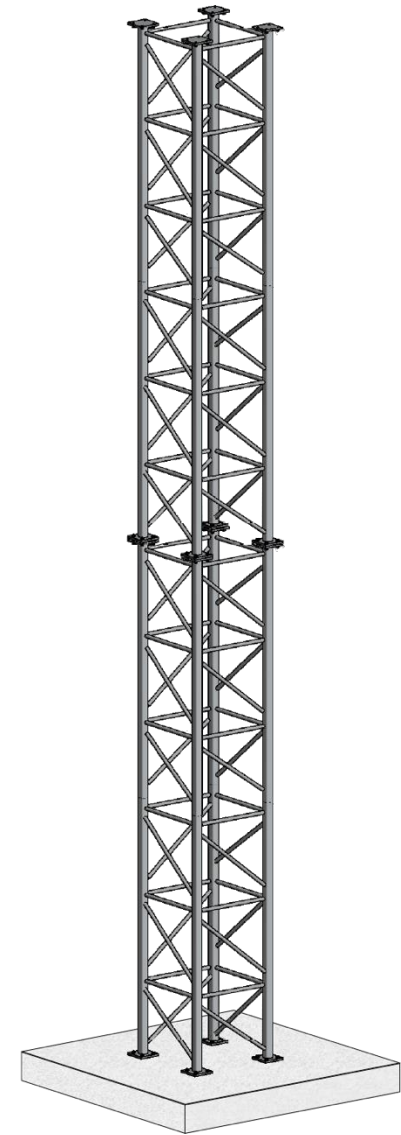

Arch324: STRUCTURES II

Welcome to Recitation session 03/20

Outline:

- Quick **Recap** of the week
- Provide the solution for the assignment (**Homework 8**)
- Answering student's questions
- Lab: **Flexural Strain**
- **Tower Project:** Test date is **March 30**

Please feel free to ask questions.

Recap of the week

Rectangular Beam Analysis

Data:

- Section dimensions – b, h, (span)
- Steel area - A_s
- Material properties – f'_c , f_y

Required:

- Nominal Strength (of beam) Moment - M_n
- Required (by load) Design Moment – M_u
- Load capacity

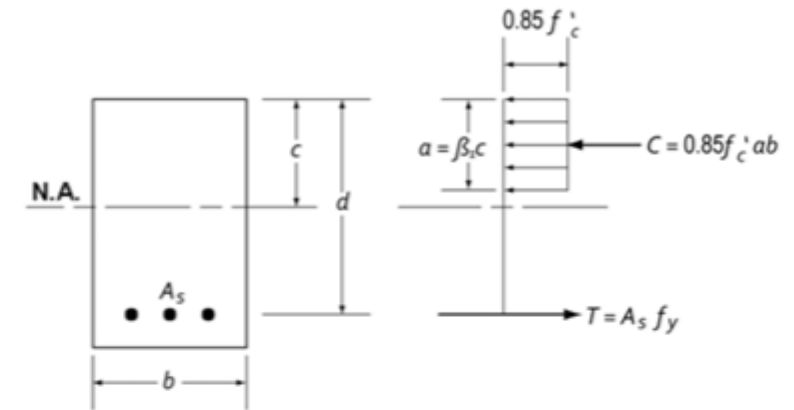

$A_{s_{min}}$:
greater of (a) and (b)

$$(a) \frac{3\sqrt{f'_c}}{f_y} b_w d$$

$$(b) \frac{200}{f_y} b_w d$$

$$c = \frac{a}{\beta_1}$$

$$\epsilon_t = \frac{d - c}{c} 0.003 \geq 0.005$$

$$a = \frac{A_s f_y}{0.85 f'_c b}$$

$$M_n = A_s f_y \left(d - \frac{a}{2} \right)$$

$$\phi M_n \geq M_u$$

$$M_u = \frac{(1.2W_{DL} + 1.6W_{LL})l^2}{8}$$

$$1.6W_{LL} = \frac{M_u 8}{l^2} - 1.2W_{DL}$$

1. Calculate d
2. Check A_s min
3. Calculate a
4. Determine c
5. Check that $\epsilon_t \geq 0.005$ (tension controlled)
6. Find nominal moment, M_n
7. Calculate required moment, $\phi M_n \geq M_u$
(if $\epsilon_t \geq 0.005$ then $\phi = 0.9$)
8. Determine max. loading (or span)

Provide the solution for the assignment – HW8

8. Concrete Beam Analysis

Analyze the given composite floor system. Using a transformed section, determine peak stress values in both concrete and steel.

DATASET: 1		-2-	-3-
simple span		30 FT	
section width, b		21 IN	
section height, h		30 IN	
max. aggregate size		0.75 IN	
bar size number		10	
the number of bars		5	
stirrup bar size number		4	
concrete cover		1.5 IN	
concrete ultimate strength, f'_c		3500 PSI	
steel yield strength, f_y		60000 PSI	

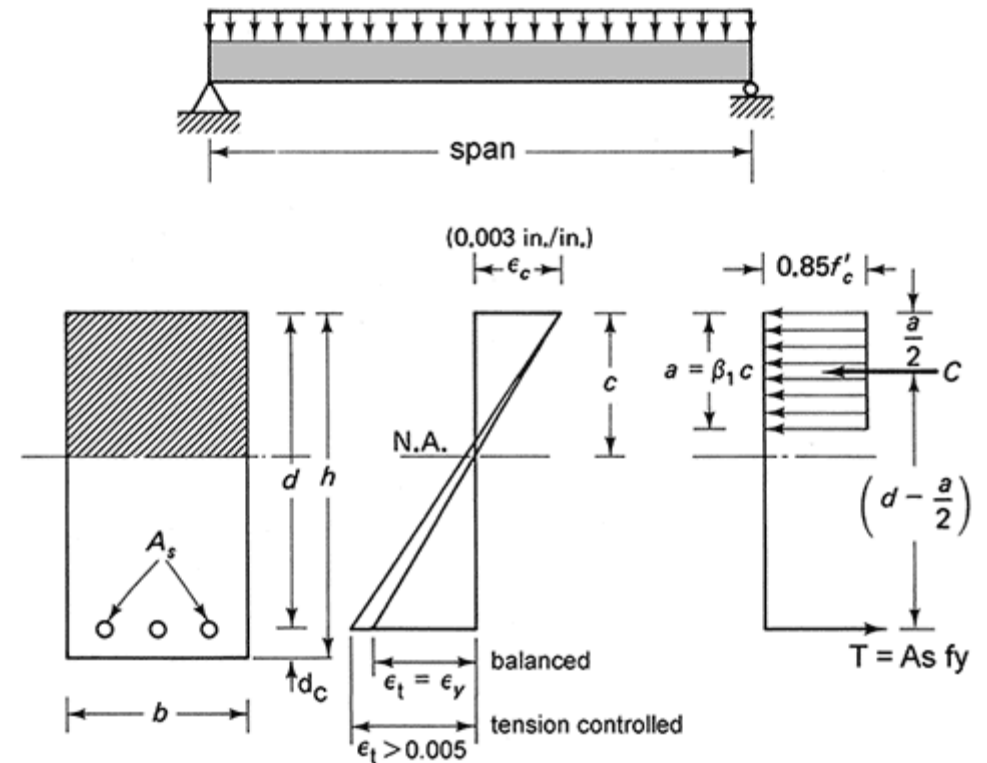

Provide the solution for the assignment – HW8

#	Question	Your Response
1	flexural steel bar diameter, db	<input type="text"/> IN
2	stirrup bar diameter	<input type="text"/> IN
3	distance from lower beam edge to center of flexural steel, dc	<input type="text"/> IN
4	distance from top beam edge to center of flexural steel, d	<input type="text"/> IN
5	minimum required area of steel, As,min (GREATER of the 2 criteria)	<input type="text"/> IN ²
6	actual area of flexural steel, As	<input type="text"/> IN ²
7	depth of concrete stress block, a	<input type="text"/> IN
8	factor beta_1	<input type="text"/>
9	distance to Neutral Axis from top of beam, c	<input type="text"/> IN
10	strain in flexural steel, epsilon_t	<input type="text"/>
11	strength reduction factor, phi	<input type="text"/>
12	tensile force in the flexural steel, T	<input type="text"/> K
13	the nominal bending moment, Mn	<input type="text"/> K-IN
14	the factored bending resistance, phi Mn	<input type="text"/> K-IN
15	the factored design moment, Mu	<input type="text"/> K-FT

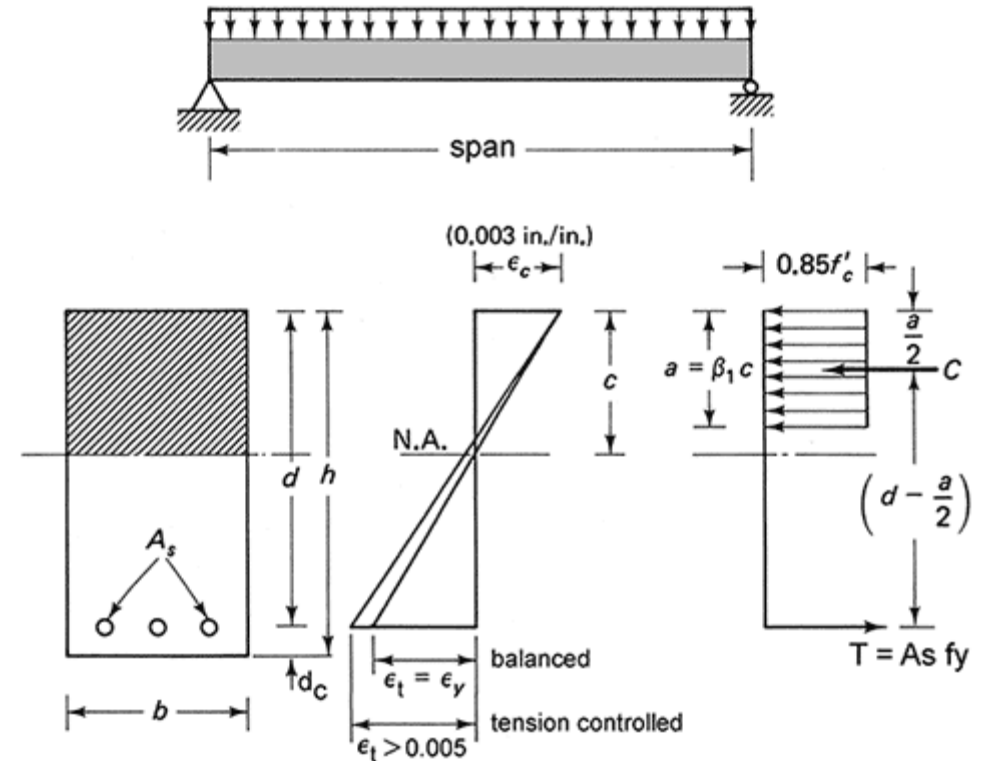

Provide the solution for the assignment – HW8

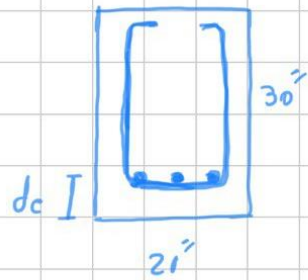

① Steel bar diameter, $d_b = 1.270$ in (Table A.2) #10

Q1

② stirrups bar diameter = 0.5 in #4

Q2

③ distance from lower beam edge to center of flexural steel, d_c

$$= \text{Cover} + \text{stirrups diameter} + \frac{\text{flexural bar diameter}}{2}$$

$$= 1.5 + 0.5 + \frac{1.270}{2} = 2.635 \text{ in}$$

Q3

④ distance from top beam edge to center of flexural steel, d

$$d = h - d_c = 30 - 2.635 = 27.365 \text{ in}$$

Q4

Table A.2 Designations, Areas, Perimeters, and Weights of Standard Bars

Bar No.	Customary Units			SI Units		
	Diameter (in.)	Cross-sectional Area (in. ²)	Unit Weight (lb/ft)	Diameter (mm)	Cross-sectional Area (mm ²)	Unit Weight (kg/m)
3	0.375	0.11	0.376	9.52	71	0.560
4	0.500	0.20	0.668	12.70	129	0.994
5	0.625	0.31	1.043	15.88	200	1.552
6	0.750	0.44	1.502	19.05	284	2.235
7	0.875	0.60	2.044	22.22	387	3.042
8	1.000	0.79	2.670	25.40	510	3.973
9	1.128	1.00	3.400	28.65	645	5.060
10	1.270	1.27	4.303	32.26	819	6.404
11	1.410	1.56	5.313	35.81	1006	7.907
14	1.693	2.25	7.650	43.00	1452	11.384
18	2.257	4.00	13.600	57.33	2581	20.238

Provide the solution for the assignment – HW8

$$\textcircled{5} (A_s)_{\min} \begin{cases} \frac{3\sqrt{f'_c}}{f_y} b_w d = \frac{3\sqrt{3500}}{60000} (21)(27.365) = 1.6998 \text{ in}^2 \\ \frac{200 b_w d}{f_y} = \frac{200 (21)(27.365)}{60000} = 1.9155 \text{ in}^2 \end{cases}$$

$$A_s \geq (A_s)_{\min} = 1.9155 \text{ in}^2$$

⑥ A_s : Actual area of flexural steel

$$A_s = \text{No. bars} \times \text{bar cross-sectional area} (\#10)$$

$$A_s = 5 \times 1.270 = 6.35 \text{ in}^2 > (A_s)_{\min} = 1.9155 \text{ in}^2$$

⑦ Calculate a : (depth of conc. stress block)

$$a = \frac{A_s f_y}{0.85 f'_c b} = \frac{(6.35)(60000)}{0.85(3500)(21)} = 6.098 \text{ in}$$

Q5

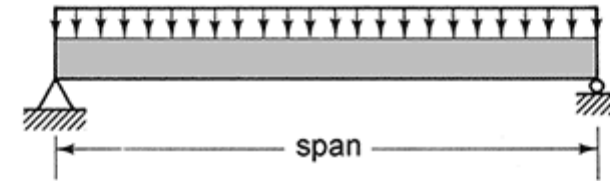

Q6

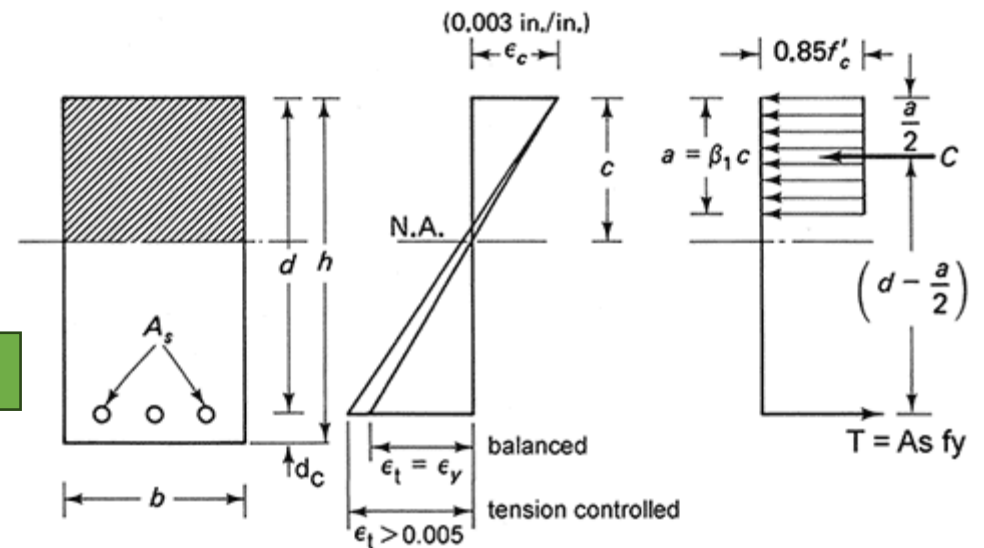

Q7

Provide the solution for the assignment – HW8

⑧ β_1 : Formula

$$\beta_1 = 0.85 - 0.05 \left(\frac{f_c' - 4000}{1000} \right)$$

$$= 0.85 - 0.05 \left(\frac{3500 - 4000}{1000} \right) = 0.875$$

⑨ c : distance to N.A from top of beam

$$c = \frac{a}{\beta_1} = \frac{6.098}{0.875} = 6.9691$$

⑩ $\epsilon_t = \frac{d-c}{c} (0.003) \geq 0.005$

$$\epsilon_t = \frac{27.365 - 6.9691}{6.9691} (0.003) = 0.00849 \geq 0.005$$

⑪ Tension Controlled
 $\phi = 0.90$

Strength reduction factor

Q8

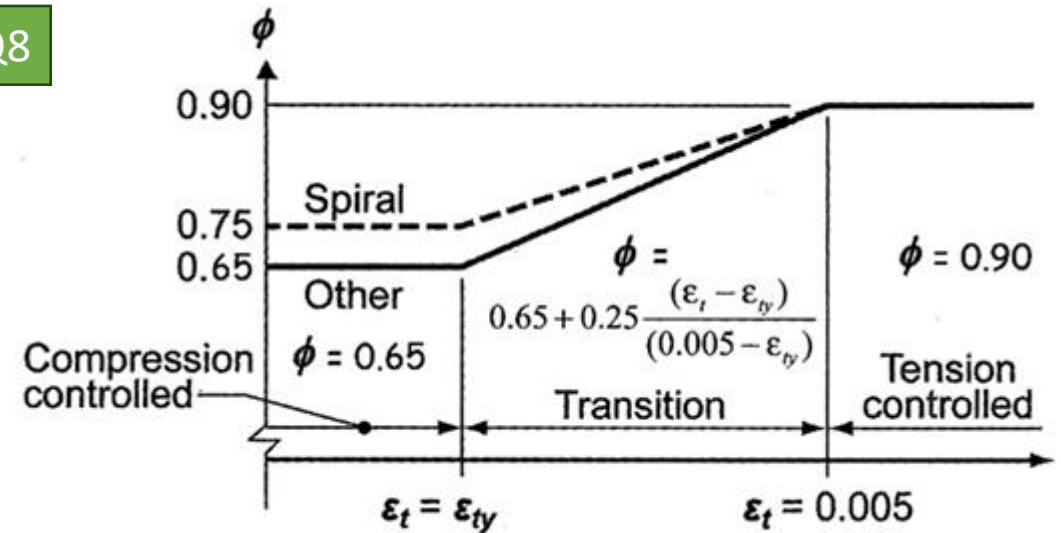

Q10

Q11

Provide the solution for the assignment – HW8

⑫ Tensile force in flexural steel, T

$$T = A_s F_y = 6.35 \times 60000 = 381000 \\ 381 \text{ kips}$$

Q12

⑬ nominal bending moment, M_n

$$M_n = A_s F_y \left(d - \frac{a}{2} \right)$$

$$M_n = (6.35) \left(\frac{60000}{\text{in}^2} \right) \left(\frac{27.365}{\text{in}} - \frac{6.098}{2} \right) = 9264396 \\ = 9264.396 \text{ k-IN}$$

Q13

⑭ $\phi M_n = 0.9 M_n = 8337.95 \text{ k-IN}$

Q14

⑮ $M_u = \phi M_n = 8337.95 \text{ k-IN} \times \frac{1}{12} = 694.82 \text{ k-FT}$

Q15

Lab : Flexural Strain

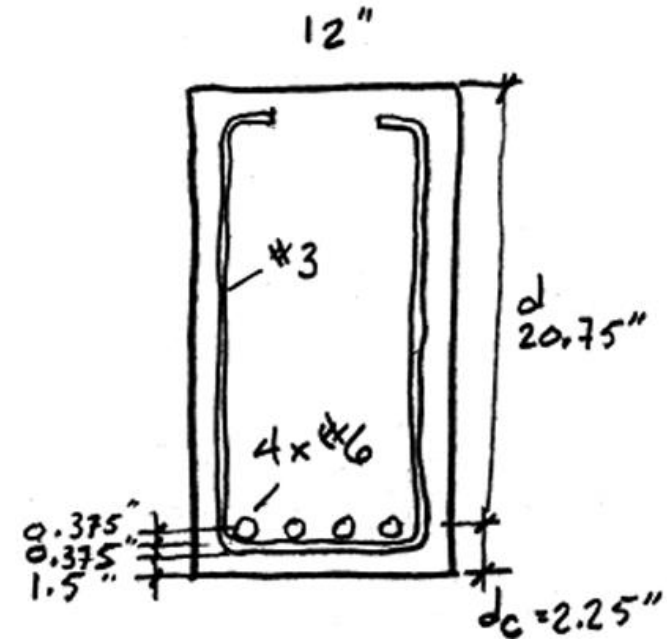

Description

This project produces a graphic representation of the strain diagram for a tension controlled concrete beam.

Goals

- To plot the compression and tension strain levels in a concrete beam
- To graphically determine the neutral axis.
- To draw the ACI "Whitney" stress block showing C and T forces.
- To compare plotted and calculated results.

Lab : Flexural Strain

Procedure

1. For the tension controlled beam analysis discussed in lecture, construct the strain diagram with $\epsilon_{cu} = 0.003$ and ϵ_t as calculated.
2. Use $f'_c = 6000$ psi and $f_y = 60000$ psi
3. Graphically determine the c distance from the top to the N.A on your diagram.
4. Make a second diagram to show the relationship of C & T forces to the strains.
5. Draw the ACI – Whitney stress block at “ a ” distance from the top.
6. Show the moment arm and calculate j using $jd = z$.

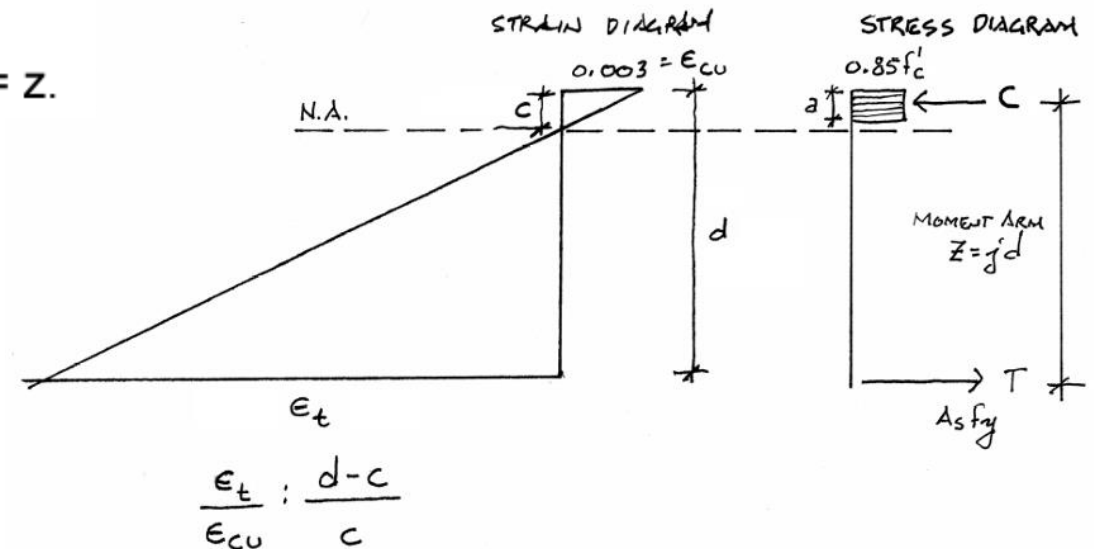
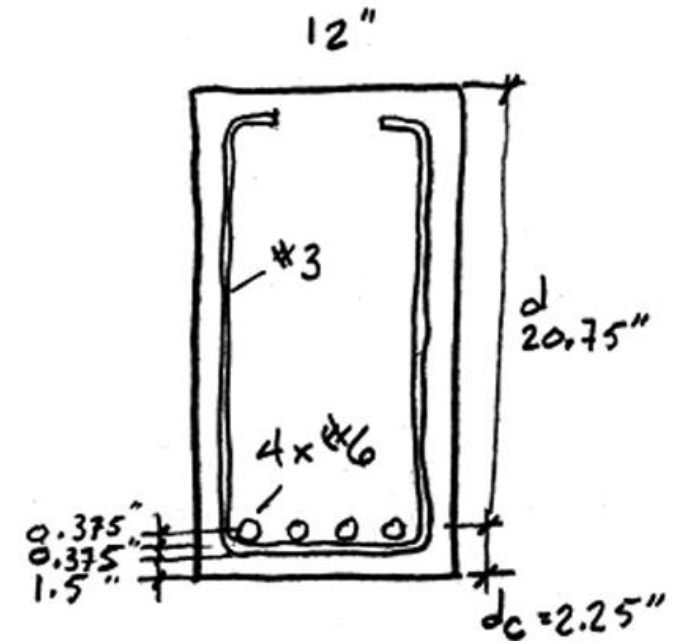

Lab : Flexural Strain

$$F_y = 60000 \quad F'_c = 6000 \text{ psi} \quad \epsilon_{cu} = 0.003$$

$$\textcircled{1} \alpha = \frac{A_s F_y}{0.85 F'_c b} \quad \textcircled{2} \beta_1 = 0.85 - 0.05 \left(\frac{F'_c - 4000}{1000} \right)$$

$$\textcircled{3} C = \frac{\alpha}{\beta_1} \quad \textcircled{4} \epsilon_t \rightarrow \frac{\epsilon_t}{\epsilon_{cu}} = \frac{d-c}{c}$$

$$\textcircled{6} \text{ Moment arm: } d - \frac{\alpha}{2}$$

$$T = A_s F_y$$

$$M_n = T \left(d - \frac{\alpha}{2} \right)$$

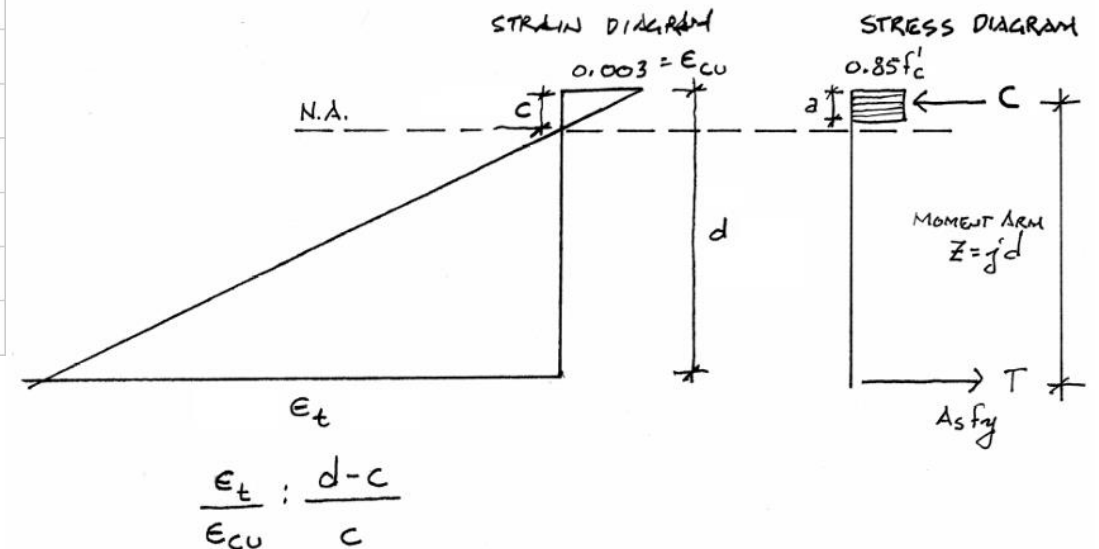
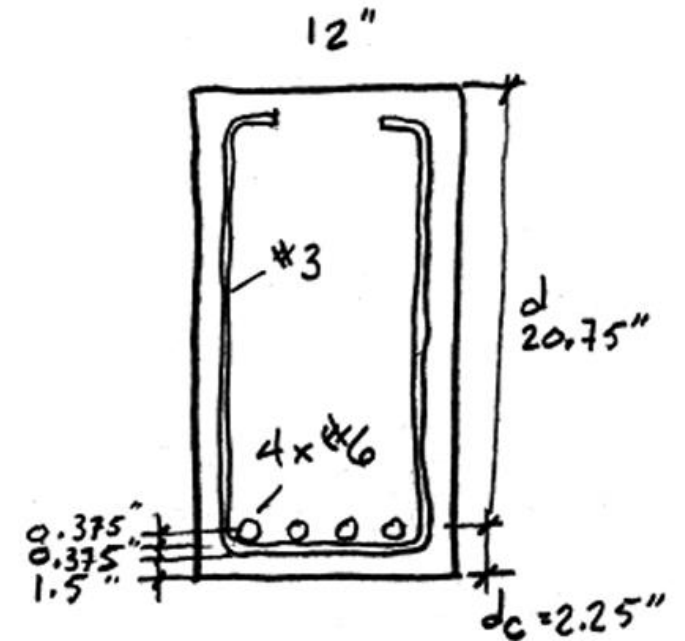

Arch324: STRUCTURES II

Thank you.

Any question?

Please feel free to ask questions.